

12TH EDITION • REVISED 5-1



# **HARDSCAPES PACKAGING AND SPECIFICATIONS GUIDE.**

PROFESSIONAL REFERENCE FOR LANDSCAPE ARCHITECTS,  
DESIGNERS, SPECIFIERS, BUYERS AND HARDSCAPE CONTRACTORS.



**WELCOME TO  
THE BACKYARD...**

YOU'RE GOING TO LOVE IT OUT HERE!

# WHAT'S INSIDE?

## Wet Cast Landscape Tiles

Barn Plank .....	6
Slate .....	7
Installation Notes .....	7

## Pavers & Slabs

Accent Paver (6 x 12) .....	16
American Brick Paver .....	14
Barrington & Minnetonka Pavers .....	9
Broadmour Pavers .....	11
Bullnose Paver .....	35
Cobble Stone Paver .....	16
Colonial Pavers/Circle Kit .....	12-13
Flagstone Paver .....	16
Holland and Holland-Eco Pavers .....	17
Lamont Paver/Circle Kit .....	14-15
Mezzano and Serano Pavers .....	10
Porcelain Pavers (NEW) .....	20-21
Tahoe and Reno Pavers (NEW) .....	10
Turfstone-Eco Paver .....	17

## Retaining Walls

Barn Plank Garden Wall .....	6
Belvedere Wall .....	30
Cap Blocks .....	32
Classic 6 and 8 Walls .....	24
Classic 8 DOT Wall and Caps .....	24
Classic Colonial 6 and 8 Walls .....	25
Contemporary Wall .....	23
Compac Wall .....	27
Cottage Stone Wall .....	26
Kodah Wall .....	30
Lakeland Wall .....	23
Legend Wall .....	27
Outcropping Wall .....	30
Recon Wall .....	29
Riverland Wall .....	22
Sapphire Wall .....	26
Standard Wall (Keystone) .....	28
Standard Wall (Versa-Lok) (NEW) .....	28
StoneHedge 6 Wall .....	26
Stonegate Wall .....	27
Vintage 6 Wall .....	22
Wall Caps .....	40

## Outdoor Living Kits

Fireplace Kits .....	42-44
Fire Ring Kits & Accessories .....	45
Grand Island Bar Series .....	46
Kitchen Cabinet Kits .....	38-41
Necessories .....	42-49
Seatwall and Pillar Kits .....	44
Summerset Pro Sizzler Grills .....	39
Table Kits .....	47
Waterfall Kits .....	47
Woodbox/Stand Kits .....	47

## Accessories

Adhesive .....	35
Alliance Gator Sand/Sealers, ect. ....	36
Bullnose Paver .....	35
Cap Blocks .....	32
Chiseled Caps and Tops .....	34
Connection Pins (Keystone) .....	24
Edgers .....	35
Geo-Grid .....	34
Grand Step .....	33
Irregular/Dimensional Steps .....	30
Sleeve-It .....	34
Snap Edge .....	34
Stepping Stones .....	33
Steps (wet cast) .....	33

## Reference

Accenting and Border Patterns .....	18
Adhesive Calculator .....	51
Classic 6 & 8 Wall Construction .....	52-54
Calculating Paver Material .....	50
Calculating Retaining Wall Material .....	51
Color Chart .....	19
Color Selector .....	30
KolorLast .....	27
Necessories .....	46
Open Graded Base Construction .....	9
Vintage 6 Wall Construction .....	55-56
Warranty, Terms & Conditions .....	57-58

<b>New/Discontinued</b> .....	4
<b>Staff Directory</b> .....	5

We manufacture and/or distribute these leading hardscape brands and accessories.

**ROCKWOOD**  
RETAINING WALLS  
*A better way.™*





# UPDATES

## PLANNING YOUR TRUCKLOAD

The following items can stack on top of other pallets but CANNOT be stacked upon due to pallet size and/or position of product on pallet:

- Antique Travertine Tiles and Bullnose
- Barn Plank Tiles and Garden Wall
- Slate Landscape Tiles and Bullnose
- Fire Ring Cap
- Cottage Stone Retaining Wall
- Stepping Stones

### LOADING NOTES:

- Grand Fire Ring Kits can stack three high
- For LTL purposes, each "spot" cannot weigh over 3,000 lbs. stacked
- All pallet weights include 50 lbs. for pallet

### FREIGHT RATES:

Whether shipping LTL or full loads, dispatchers will find the most competitive freight rate available. Do you need a few pallets to complete a job but can't wait for a full truckload order? Dispatchers will work to get what you need shipped quickly via LTL carrier. LTL shipments less than 15,000 lbs. and 10 pallets are shipped at current rates throughout the Midwest at 1-3 day delivery.

## NEW COLORS/PRODUCTS

**Standard Wall** (Versa-Lok) - Moonlight Gray, Buff, Carmel

**Glacier Wall** (Recon) - Summer 2021

**Summerset Garden Wall** (Silver Creek) - Summer 2021

**Sapphire 6 Wall** (Rockwood) - Cascade

**Vintage 6 Split Face** (Rockwood) - Beechwood, Bluestone, Cascade, Santa Fe

**6 x 12 Accent Paver** (smooth top) - Natural

**Holland paver** - Natural

**Colonial 3/4 sq. paver** - Natural

**Bullet Edger** - Natural

**Victorian Fire Pit** - Onyx

## DISCONTINUED COLORS

- Lakeland Wall (Desert)
- Riverland Wall (Desert)

## DISCONTINUED PRODUCTS (non-stocking)

- Necessaries:
  - Outdoor Wood-fired Ovens
  - Oven Toolkit
  - Contemporary Fireplace
- Classic 8 Chisled Face wall
- Antique Travertine Garden Wall, Step and Firepit Kit

## SPECIAL ORDER ITEMS

- Broadmour 10cm Pavers
- Colonial 8cm Paver
- Classic 8 Colonial Wall
- Holland 8cm Paver
- Turfstone Eco Paver
- Big Step
- Keystone Standard Wall
- Legend Wall
- Premier 8 Wall
- StoneHedge 6 Wall

## PALLET COUNTS

- Unit totals and weights have changed on:
- Vintage 6 Wall
  - 4" Wall Cap
  - Classic Edger



**Rochester**  
Concrete Products™

**Please Note:** Our products are made from solid color concrete for lasting appearance and durability. Photographs and depictions contained herein are for representation only. Refer to actual product samples when making color selection. Product dimensions given are nominal in inches, weights in pounds.

The information presented here has been prepared for the benefit of customers interested in Rochester Concrete Products, it was reviewed carefully prior to publication. Rochester Concrete Products assumes no liability for its accuracy or completeness. Final determination of the suitability of any information or material for the use contemplated, or for its manner of use, is the sole responsibility of the user. Not all products available in all areas. Product availability and specifications subject to change without notice.

# WHO'S WHO?

---

## SALES STAFF

**Chad Peterson** (WI)  
262-758-2354  
chad.peterson@rochesterpcp.com

**Crystal Kjellesvik** (IL)  
630-400-4988  
crystal.kjellesvik@rochesterpcp.com

**Chad Miller** (WI)  
262-303-1099  
chad.miller@rochesterpcp.com

**Glen Nevala** (MN, SD, ND)  
612-702-4115  
glen.nevala@rochesterpcp.com

**Jeremy Bickner** (MN)  
612-916-7449  
jeremy.bickner@rochesterpcp.com

**Jim Weidner** (Commercial Sales)  
507-951-4374  
jweidner@moderra.com

**John Sheahan** (WI)  
507-279-2950  
john.sheahan@rochesterpcp.com

**Kurt Glave** (IL, IN)  
847-401-3741  
kurt.glave@rochesterpcp.com

**Scott Gengler** (IA, NE)  
507-269-6982  
scott.gengler@rochesterpcp.com

**Travis Lawrence** (MN)  
612-801-9026  
travis.lawrence@rochesterpcp.com

**Chris Staszuk** (Midwest & E. USA)  
517-249-0777  
cstaszuk@rockwoodwalls.com

## DISPATCH

**Becky Myre** (Jordan)  
952-492-4082  
becky.myre@rochesterpcp.com

**Cherey Justmann** (Beaver Dam)  
920-386-3104  
cherey.justmann@rochesterpcp.com

**Jaime Martinez** (Rochester)  
507-424-4693  
jaime.martinez@rochesterpcp.com

**Karla Portillo** (Rochester)  
507-535-1489  
karla.portillo@rochesterpcp.com

**Linda Baker** (Beaver Dam)  
920-386-3105  
linda.baker@rochesterpcp.com

**Mark Straub** (Jordan)  
952-492-3636  
mark.straub@rochesterpcp.com

**Tanya Kapfer** (Thorp)  
715-669-5552  
tanya.kapfer@rochesterpcp.com

## MANUFACTURING

**Corp. Office/Rochester Plant**  
7200 N Broadway Ave.  
Rochester, MN 55906  
507-288-8850  
507-535-1487 fax

**Beaver Dam Plant**  
W6558 Hwy 33, Juneau, WI 53039  
920-386-3333  
920-386-4612 fax

**Thorp Plant**  
N14665 Dickerson Ave., Thorp, WI 54771  
715-669-5552  
715-669-7135 fax

**Jordan Plant**  
3535 Bluff Drive, Jordan, MN 55352  
952-492-3636  
952-492-3668 fax

## SUPPORT STAFF

**Crystal Mathews** (Warranties and Samples)  
507-535-1482  
crystal.mathews@glsindustries.net

**David Spies** (Marketing Director)  
507-535-3507  
david.spies@rochesterpcp.com

**Jessica Spading** (Online Marketing)  
507-535-3509  
jspading@rockwoodwalls.com

**Justin Rueth** (Web)  
507-535-3524  
jrueth@rockwoodwalls.com

**Kim Schumacher** (Acct's Receivable)  
507-535-1493  
kim.schumacher@glsindustries.net

**Online Calculator:**  
[www.rochesterpcp.com/calculator](http://www.rochesterpcp.com/calculator)

**Online Order Form:** Contact your Regional sales representative

**[www.rochesterpcp.com](http://www.rochesterpcp.com)**

# Barn Plank Landscape Tiles

Silver Creek Stoneworks

## Features

- Deep splits and detailed grain top and sides, three faces each
- Will never rot or warp
- For paths, patios, pools, caps and overlays
- Matching step block, garden wall and fire pit kit
- Strong and durable 10,000 psi concrete

## Colors

- Mahogany (color protected)
- Weathered Gray (color protected)



Use roller compactor or buffer pad when compacting.

Available in partial pallets. CANNOT be double stacked.

To calculate pieces divide total sq. ft. by 5.20

Barn Plank tiles are manufactured with a surface applied protectant to help resist the harmful effects of time, Mother Nature, acid rain and stains.

**Gap tiles a minimum of 1/4"**

Size/Name	Dimensions	Area (ea.)	Weight (ea.)	Units/pallet	Weight/pallet
Small	15.50 x 9.75 x 2" H	1.05 sq. ft.	24 lbs.	40 (42 sq. ft.)	1,010 lbs.
Medium	23.375 x 9.75 x 2" x H	1.59 sq. ft.	33 lbs.	20 (31.80 sq. ft.)	710 lbs.
Large	35 x 9.75 x 2" x H	2.37 sq. ft.	52 lbs.	20 (47.40 sq. ft.)	1,090 lbs.

Dimensions shown are nominal. Pallet square footage is accurate, layers and bands square footages have been rounded to nearest whole number.

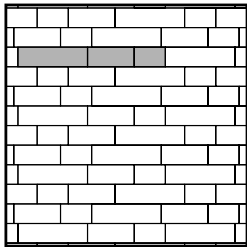

**Pattern 1**  
Small = 20.9%  
Medium = 31.6%  
Large = 47.4%

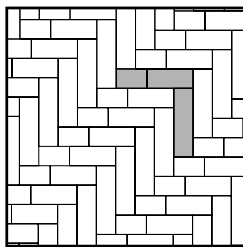

**Pattern 2**  
Small = 20.9%  
Medium = 31.6%  
Large = 47.4%

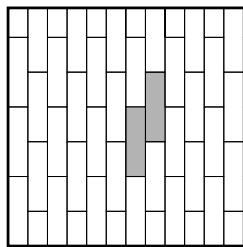

**Pattern 3**  
Large = 100%

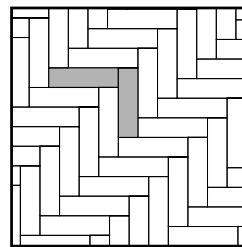

**Pattern 4**  
Large = 100%

# Barn Plank Garden Wall

Silver Creek Stoneworks

- Deep splits and detailed grain on five sides
- Smooth radius, 90° corners all sides
- Matching landscape tiles and step
- **Matching Fire Pit Kit on page 45**

## Colors

- Mahogany
- Weathered Gray

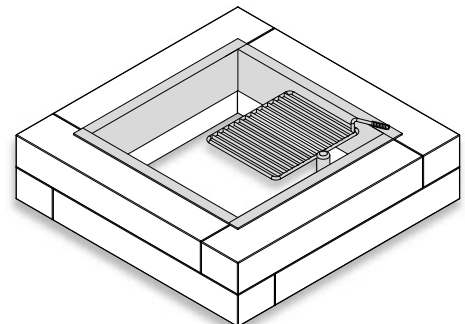
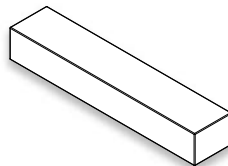

Barn Plank Garden Wall is manufactured with a surface applied protectant to help resist the harmful effects of time, Mother Nature, acid rain and stains.

Name	Dimensions	Area (ea.)	Weight (ea.)	Units/pallet	Weight/pallet
Barn Plank Garden Wall	40 x 8 x 6" H	1.66 sq. ft.	162 lbs.	16 (26.56 sq. ft.)	2,650 lbs.

# Slate Landscape Tiles

Silver Creek Stoneworks

## Features

- Four sizes with 23 unique faces plus coping
- Strong and durable 10,000 psi concrete
- Detailed slate top, chiseled sides
- No spacers, easily gapped
- Unique 24" x 36" slab

## Colors

- Bluestone
- Cream
- Fond du Lac

**Gap tiles a minimum of 1/4"**



Use roller compactor or buffer pad when compacting.

Available in partial pallets. CANNOT be double stacked.

Size/Name	Dimensions	Area (ea.)	Weight (ea.)	Units/pallet	Weight/pallet
Small Sq.	12 x 12 x 1.5" H	1 sq. ft.	19 lbs.	48 (48 sq. ft.)	938 lbs.
Rectangle	24 x 12 x 1.5" H	2 sq. ft.	38 lbs.	24 (48 sq. ft.)	962 lbs.
Large Sq.	24 x 24 x 1.5" H	4 sq. ft.	77 lbs.	24 (96 sq. ft.)	1,898 lbs.
XL (not shown)	24 x 36 x 1.5" H	6 sq. ft.	106 lbs.	16 (96 sq. ft.)	1,746 lbs.
Bullnose	14 x 14 x 1.5" H	1.36 sq. ft.	25 lbs.	24 (32.66 sq. ft.)	650 lbs.

Dimensions shown are nominal. Pallet square footage is accurate, layers and bands square footages have been rounded to nearest whole number.

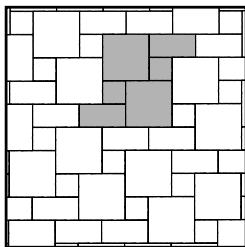

**Pattern 1**  
Small sq. = 14%  
Rectangle = 29%  
Lg. Sq. = 57%

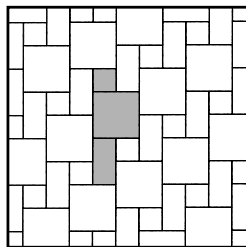

**Pattern 2**  
Small sq. = 14%  
Rectangle = 29%  
Lg. Sq. = 57%

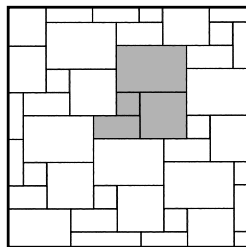

**Pattern 3**  
Small sq. = 7.69%  
Rectangle = 15.39%  
Lg. Sq. = 30.77%  
XL = 46.15%

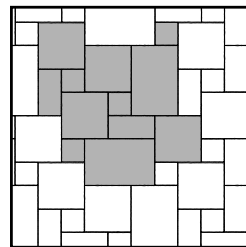

**Pattern 4**  
Small sq. = 11.1%  
Rectangle = 11.1%  
Lg. Sq. = 44.4%  
XL = 33.3%

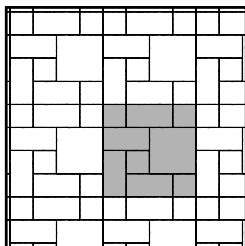

**Pattern 5**  
Small sq. = 25%  
Rectangle = 50%  
Lg. Sq. = 25%

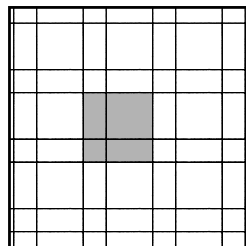

**Pattern 6**  
Small sq. = 11.2%  
Rectangle = 44.4%  
Lg. Sq. = 44.4%



### IMPORTANT INSTALLATION NOTES:

- Gap Silver Creek Landscape Tiles 1/4" to aid leveling and aesthetics
- Pull from multiple pallets and rotate tiles to enhance random appearance
- Pavers and slabs with embossed surfaces are more susceptible to scuff marks from plate compactors. Always use a roller compactor or a protective mat between the plate and paver surface when compacting.



# Antique Travertine Landscape Tiles

Silver Creek Stoneworks

## Features

- Three sizes w/eighteen unique faces
- Detailed travertine top and sides, smooth honed surface
- For paths, patios, pools and overlays
- Matching coping block
- Strong and durable 10,000 psi concrete



Partial pallet quantities available, pallets CANNOT be double stacked.

## Colors

- Ivory
- Natural

**Gap tiles a minimum of 1/4"**

*Use roller compactor or buffer pad when compacting.*

Size/Name	Dimensions	Area (ea.)	Weight (ea.)	Units/pallet	Weight/pallet
Small	12 x 24 x 2" H	2 sq. ft.	46 lbs.	20 (40 sq. ft.)	970 lbs.
Medium	18 x 24 x 2" H	3 sq. ft.	70 lbs.	18 (54 sq. ft.)	1,310 lbs.
Large	24 x 24 x 2" H	4 sq. ft.	88 lbs.	18 (72 sq. ft.)	1,634 lbs.
Bullnose	24 x 12 x 2" H	2 sq. ft.	43 lbs.	20 (40 sq. ft.)	910 lbs.

Dimensions shown are nominal. Pallet square footage is accurate, layers and bands square footages have been rounded to nearest whole number.

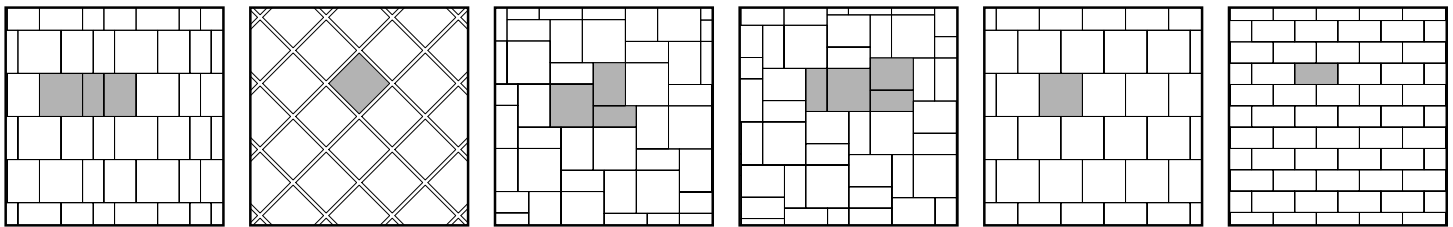

**Pattern 1**  
Small = 22.26%  
Medium = 33.33%  
Large = 44.4%

**Pattern 2**  
Large = 100%

**Pattern 3**  
Small = 22.26%  
Medium = 33.33%  
Large = 44.4%

**Pattern 4**  
Small = 36.2%  
Medium = 27.3%  
Large = 36.5%

**Pattern 5**  
Large = 100%

**Pattern 6**  
Small = 100%

**Build fast and efficiently by using open graded base material and large format pavers.**

Open graded paver base construction is wet weather friendly, costs less than conventional base and can save as much as 35 labor hours per week. In six months, you could gain as much as 840 labor hours.

Choose large format pavers and install more jobs. See the time study comparison at: [www.rochestercp.com/efficiency](http://www.rochestercp.com/efficiency)

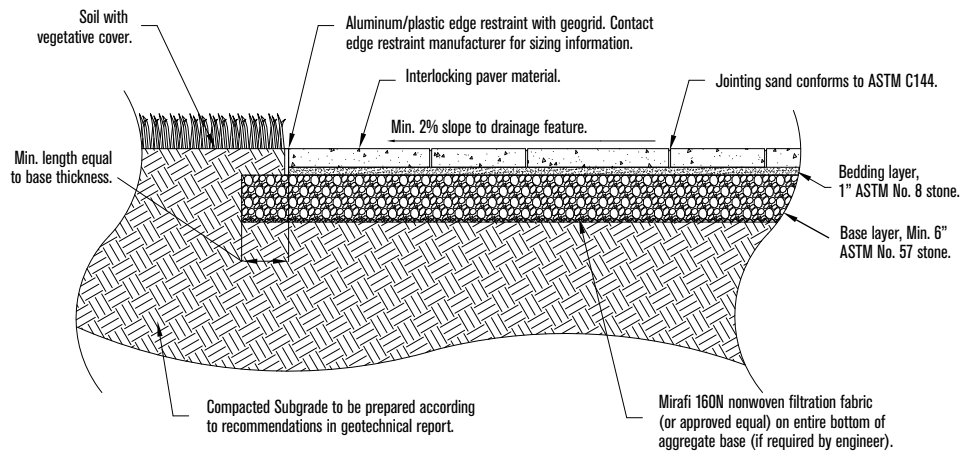

**Design Notes:**

1. Cross-section shown as suitable for sidewalks and patios.
2. Depth of aggregate base subject to site specific conditions such as soil conditions, groundwater levels, climate conditions, etc.
3. Depending on the permeability of subgrade soils, drain pipes should be placed within the aggregate base. Drainage needs should be verified with the geotechnical engineer. Drain pipes must be available to daylight via gravity flow to the surface or be connected to a catch basin.
4. Jointing sand that conforms to a ASTM C144 may be used in pedestrian applications. Contact your local sales representative.



# Minnetonka and Barrington Pavers/Slabs 6cm

Interlock Concrete Products



## Features

- Three-piece, one-pallet systems
- Chamfered/irregular edge
- Auto spacers, 1/8" joint
- Suitable for paths, patios, pool decks
- 6 x 12" Accent pavers

Available by pallet or layer.

## Colors

- Antique Brown w/KolorLast
- Beechwood w/KolorLast
- Bluestone w/KolorLast
- Cascade w/KolorLast
- Santa Fe w/KolorLast



**Barrington = Smooth Top**



**Minnetonka = Slate Top**

*Use roller compactor or buffer pad when compacting.*



**6 x 12 Accent**  
Smooth or Slate Top

## 6 x 12 Colors (Separate Pallets)

- Brown w/KolorLast
- Buff w/KolorLast
- Onyx w/KolorLast
- Natural (Smooth only)

Size/Name	Dimensions	Area (ea.)	Weight (ea.)	Units/layer	Area/layer	Layers	Units/pallet	Weight/pallet
Small	8 x 16 x 2.375" H	0.89 sq. ft.	24.5 lbs.	2	-	-	20	
Medium	16 x 16 x 2.375" H	1.78 sq. ft.	49 lbs.	2	10.2 sq. ft.	10	20 (102 sq. ft.)	3,000 lbs.
Large	16 x 24 x 2.375" H	2.67 sq. ft.	73.5 lbs.	2	-	-	20	
6 x 12	5.75 x 11.5 x 2.375" H	0.46 sq. ft.	13 lbs.	21	9.66 sq. ft.	10	210 (97 sq. ft.)	2,780 lbs

Dimensions shown are nominal. Pallet square footage is accurate, layers and bands square footages have been rounded to nearest whole number.

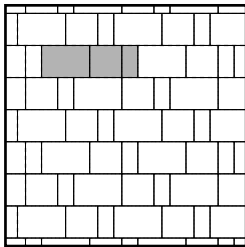

**Pattern 1**  
Small = 16.6%  
Medium = 33.33%  
Large = 50.7%

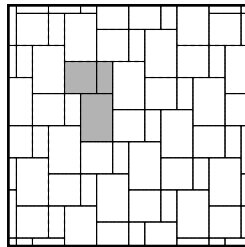

**Pattern 2**  
Small = 16.6%  
Medium = 33.33%  
Large = 50.7%

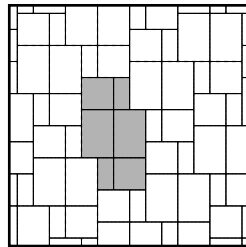

**Pattern 3**  
Small = 16.6%  
Medium = 33.33%  
Large = 50.7%

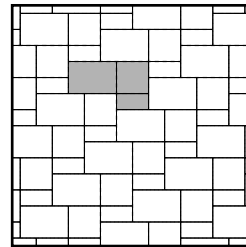

**Pattern 4**  
Small = 16.6%  
Medium = 33.33%  
Large = 50.7%

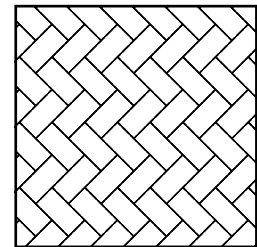

**Herringbone**  
6 x 12 = 100%

**KolorLast protected pavers live up to the damaging effects of time, Mother Nature and decades of use and abuse.**



## KolorLast Protected Pavers Are:

- Fade Resistant
- Stain Resistant
- Acid Rain Resistant
- Salt Resistant
- Spalling Resistant
- Inhibits Efflo and Poly Haze

## KolorLast Pavers

American Brick .....	All Colors
Barrington & Minnetonka .....	All Colors
Broadmour .....	Onyx
Broadmour Plank .....	Onyx
Cobble Stone .....	Onyx
Colonial .....	Onyx
Holland .....	Onyx
Mezzano and Serano .....	All Colors

# Mezzano and Serano Pavers 6cm

Interlock Concrete Products

## Features

- Three-piece, one pallet system
- Chamfered/irregular edge
- Auto spacers, 1/8" joint
- Suitable for vehicular applications
- 6 x 12" Accent pavers

Available by pallet or layer.

## Colors

- Antique Brown w/KolorLast
- Beechwood w/KolorLast
- Bluestone w/KolorLast
- Cascade w/KolorLast
- Santa Fe w/KolorLast



**Serano = Smooth Top**



**Mezzano = Slate Top**

Use roller compactor or buffer pad when compacting.



**6 x 12 Accent Colors** (smooth or slate top)

- Brown, Buff or Onyx w/KolorLast
- Natural (smooth only)

Size/Name	Dimensions	Area (ea.)	Weight (ea.)	Units/layer	Area/layer	Layers	Units/pallet	Weight/pallet
Small	5.75 x 5.75 x 2.375" H	0.23 sq. ft.	6 lbs.	6	1.38 sq. ft.	-	60	
Medium	5.75 x 11.5 x 2.375" H	0.46 sq. ft.	13 lbs.	6	2.76 sq. ft.	10	60 (97 sq. ft.)	2,685 lbs.
Large	11.5 x 11.5 x 2.375" H	0.92 sq. ft.	25 lbs.	6	5.52 sq. ft.	-	60	
6 x 12	5.75 x 11.5 x 2.375" H	0.46 sq. ft.	13 lbs.	21	9.66 sq. ft.	10	210 (97 sq. ft.)	2,780 lbs.

Dimensions shown are nominal. Pallet square footage is accurate, layers and bands square footages have been rounded to nearest whole number.

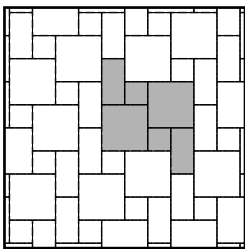

**Pattern 1**  
Small = 14%  
Medium = 29%  
Large = 57%

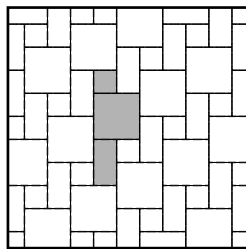

**Pattern 2**  
Small = 14%  
Medium = 29%  
Large = 57%

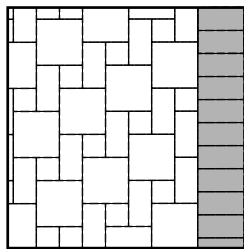

**Pattern 2**  
Soldier Course Border

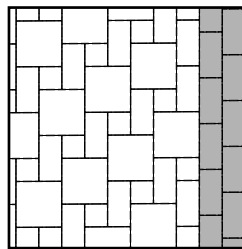

**Pattern 2**  
Double Sailor Course Border

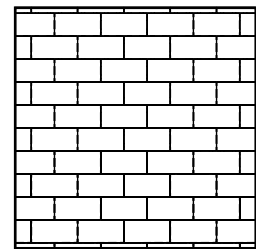

**Running Bond**  
6 x 12 = 100%

# Reno and Tahoe Pavers 6cm

Interlock Concrete Products

## Features

- Three-piece, one pallet systems
- Micro-chamfered, straight edge
- Auto spacers, 3/16" joint
- Smooth or slate embossed surfaces
- Suitable for vehicular applications

Available by pallet or layer.

## Colors:

- Beechwood
- Cascade
- Santa Fe



**Reno = Smooth Top**

**Tahoe = Slate Top**

Use roller compactor or buffer pad when compacting

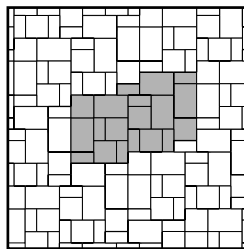

**Pattern 1**

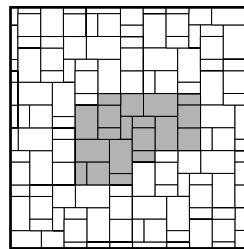

**Pattern 2**

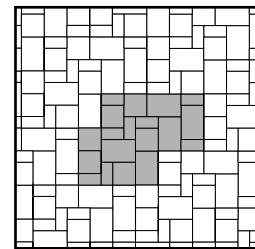

**Pattern 3**

Size	Face Area	Units/Layer	Layers	Pallets
4.875 x 9.875 x 2.375" H	0.33 sq. ft.	8 (2.67 sq. ft.)		
9.875 x 9.875 x 2.375" H	0.67 sq. ft.	6 (4.06 sq. ft.)	8 (11.75 sq. ft.)	94 sq. ft. (2,525 lbs.)
14.75 x 9.875 x 2.375" H	1.01 sq. ft.	5 (5.05 sq. ft.)		

# Broadmour Pavers 6cm



Interlock Concrete Products

## Features

- Smooth top, chamfered edges
- Auto spacers, narrow joint
- Lays quickly, patterned or random

Available by pallet or layer.

## Colors

- Cascade
- Natural
- Onyx w/KolorLast



## Plank Colors (10cm)

- Beechwood
- Cascade
- Natural
- Onyx w/KolorLast



Broadmour (6cm)	Size	Face Area	Weight	Units/Layer	Layer	Layers	Units/Pallet	Pallet Weight
Small	6 x 12 x 2.375" H	0.5 sq. ft.	15.65 lbs.	24	12 sq. ft.	6	144 (72 sq. ft.)	2,304 lbs.
Medium	12 x 12 x 2.375" H	1.0 sq. ft.	30.4 lbs.	9	9 sq. ft.	10	90 (90 sq. ft.)	2,790 lbs.
Large	24 x 12 x 2.375" H	2 sq. ft.	59 lbs.	6	12 sq. ft.	8	48 (96 sq. ft.)	2,880 lbs.
Large Sq.	24 x 24 x 2.375" H	4 sq. ft.	113.5 lbs.	2	8 sq. ft.	10	20 (80 sq. ft.)	2,320 lbs.
<b>Plank (10cm)</b>	<b>18 x 3 x 4" H</b>	0.36 sq. ft.	17.3 lbs.	22	7.92 sq. ft.	6	132 (47.5 sq. ft.)	2,130 lbs.

Broadmour Plank is high flow rate permeable. Not suitable for vehicular.

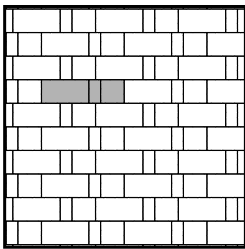

Small = 14.3%  
Medium = 28.57%  
Large = 57.14%

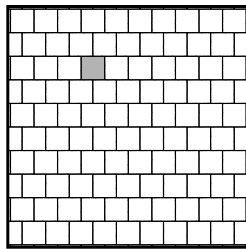

**Running Bond**  
Square = 100%

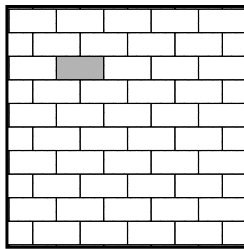

**Running Bond**  
Rectangle = 100%

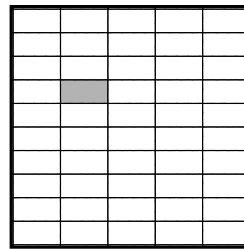

Rectangle = 100%

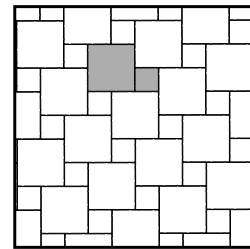

Small = 20%  
Large Sq. = 80%

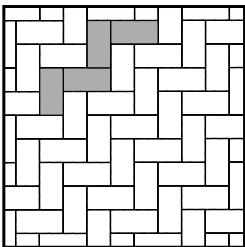

**Herringbone**  
Rectangle = 100%

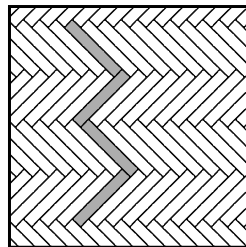

**Herringbone**  
Plank = 100%

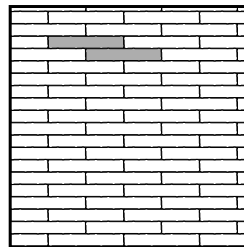

**Running Bond**  
Plank = 100%

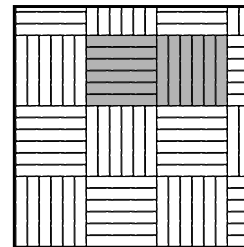

**Parquet**  
Plank = 100%



# Broadmour Pavers 10cm (special order)

10cm Broadmour pavers can be made in any color with or without KolorLast.  
Minimum quantity required, customer must take entire production run. Returns not allowed.

- Suitable for heavy vehicular applications

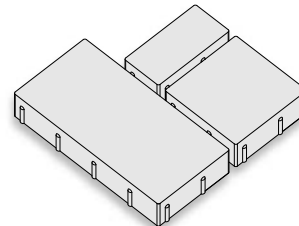

## Broadmour XXL (10cm)

Small	6 x 12 x 4" H	0.5 sq. ft.	22.93 lbs.	15	7.17 sq. ft.	6	90 (43 sq. ft.)	2,050 lbs.
Medium	12 x 12 x 4" H	1.0 sq. ft.	46.22 lbs.	9	8.67 sq. ft.	6	54 (52 sq. ft.)	2,500 lbs.
Large	24 x 12 x 4" H	2 sq. ft.	92 lbs.	4	7.67 sq. ft.	6	24 (46 sq. ft.)	2,270 lbs.

Dimensions shown are nominal. Pallet square footage is accurate, layers and bands square footages have been rounded to nearest whole number.

# Colonial Paver 6cm

Interlock Concrete Products



## Features

- Four-sizes (separate pallets)
- Dimpled top, irregular/radius edge
- Auto spacers, 1/16" joint
- Suitable for vehicular applications
- Circle kits available

Available by pallet or band.

## Colors

- Antique Copper
- Beechwood
- Carmel (discontinued)
- Moonlight Gray

## Accent Colors (3/4 sq. and rectangle)

- Brown\*
- Buff\*
- Onyx\* w/KolorLast
- Natural (NEW)



Name	Size	Face Area	Weight	Units/Band	Bands/Pallet	Units/Pallet	Pallet Weight
Half Square	6.30 x 3.15 x 2.375" H	0.14 sq. ft.	3 lbs.	50 (6.86 sq. ft.)	7	350 (48 sq. ft.)	1,300 lbs.
3/4 Square*	6.30 x 4.65 x 2.375" H	0.20 sq. ft.	6 lbs.	56 (11.4 sq. ft.)	7	392 (80 sq. ft.)	2,180 lbs.
Square	6.30 x 6.30 x 2.375" H	0.28 sq. ft.	7 lbs.	50 (14 sq. ft.)	7	350 (98 sq. ft.)	2,690 lbs.
Rectangle*	6.30 x 9.45 x 2.375" H	0.41 sq. ft.	12 lbs.	45 (18.4 sq. ft.)	5	225 (92 sq. ft.)	2,650 lbs.

Dimensions shown are nominal. Pallet square footage is accurate, layers and bands square footages have been rounded to nearest whole number.

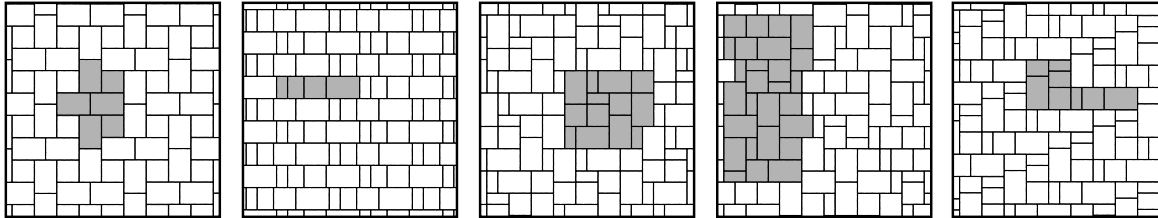

### Pattern 1

Square = 25%  
Rectangle = 75%

### Pattern 2

Half square = 13.37%  
3/4 square = 19.75%  
Square = 26.75%  
Rectangle = 40.13%

### Pattern 3

Half square = 14.81%  
Square = 29.63%  
Rectangle = 55.56%

### Pattern 4

Half square = 14.55%  
Square = 36.36%  
Rectangle = 49.09%

### Pattern 5

Half square = 13.37%  
3/4 square = 19.75%  
Square = 26.75%  
Rectangle = 40.13%

# Colonial Paver 8cm (special order)

Interlock Concrete Products

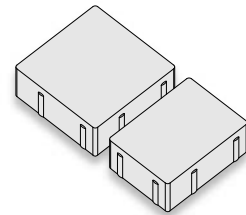

## Features

- Auto spacers, 1/8" joint
- Dimpled top, radius edge
- Suitable for vehicular applications

8cm Colonial pavers can be made in any color with or without KolorLast. Set-up fee and minimum quantity required, customer must take entire production run. Returns not allowed.

Name	Size	Face Area	Weight	Units/Band	Bands/Pallet	Unit/Pallet	Pallet Weight
Square	6.30 x 6.30 x 3.125" H	0.28 sq. ft.	10 lbs.	35	7 (9.71 sq. ft.)	245 (68 sq. ft.)	2,560 lbs.
Rectangle	6.30 x 9.45 x 3.125" H	0.41 sq. ft.	16 lbs.	35	5 (14.4 sq. ft.)	175 (72 sq. ft.)	2,750 lbs.

Dimensions shown are nominal. Pallet square footage is accurate, layers and bands square footages have been rounded to nearest whole number.

# Colonial Circle 6cm

Interlock Concrete Products



## Features

- Auto spacers, 1/16" joint
- Expand to any size
- Available by pallet or band/layer
- Starter circle kit creates a 2 course, 2.64' dia. circle
- Six starter kits/pallet

## Colors

- Antique Copper
- Moonlight Gray
- Beechwood

Note: 13.25 ft. dia. circle\* (12 courses) requires starter circle kit, plus one pallet of large circle (wedges), plus one pallet of 3/4 squares.

Pallet	Size	Weight	Units	Layers-Bands	Units/Pallet	Pallet Weight
Starter Circle Kit**	(Center + course 1 & 2)	Mixed	30/layer	6 layers/pallet	180 (36 sq. ft.)	1,060 lbs.
Large Circle (wedges)	6.3 x 5.2 x 2.375" H	6 lbs. (0.23 sq. ft.)	40/layer	7 layers/pallet	280 (56 sq. ft.)	1,550 lbs.
3/4 Squares	6.30 x 4.65 x 2.375" H	6.66 lbs. (0.20 sq. ft.)	56/band	7 bands/pallet	392 (80 sq. ft.)	2,180 lbs.

\*\*Starter Circle pallet includes 6 starter circle kits

## STARTER CIRCLE KIT

Course	Diameter	Area	Large Circle (Wedges)	3/4 Squares
Center	0.53 ft.	0.22 sq. ft.	1	-
1*	1.58 ft.	1.97 sq. ft.	8	-
2*	2.64 ft.	5.48 sq. ft.	16	-

ADDITIONAL COURSES	Diameter	Area	Units/course (layers needed)	Bands
3	3.70 ft.	10.75 sq. ft.	26 (1 Layer)	-
4	4.76 ft.	17.78 sq. ft.	34 (2 Layers)	-
5	5.82 ft.	26.57 sq. ft.	21 (2 Layers)	1 Band
6*	6.88 ft.	37.12 sq. ft.	26 (3 Layers)	1 Band
7	7.93 ft.	49.43 sq. ft.	30 (4 Layers)	2 Bands
8*	8.99 ft.	63.50 sq. ft.	34 (5 Layers)	2 Bands
9	10.05 ft.	79.33 sq. ft.	38 (6 Layers)	3 Bands
10	11.11 ft.	96.91 sq. ft.	42 (1 Pallet)	4 Bands
11	12.17 ft.	116.26 sq. ft.	1 Pallet	5 Bands
12	13.25 ft.	137.37 sq. ft.	1 Pallet	1 Pallet
13	14.28 ft.	160.23 sq. ft.	1 Pallet	1 Pallet + 2 Bands
14	15.34 ft.	184.86 sq. ft.	1 Pallet	1 Pallet + 4 Bands
15	16.4 ft.	211.25 sq. ft.	1 Pallet	1 Pallet + 6 Bands
16	17.46 ft.	239.38 sq. ft.	1 Pallet	2 Pallet s+ 2 Bands
17	18.52 ft.	269.29 sq. ft.	1 Pallet	2 Pallets + 4 Bands
18	19.58 ft.	300.95 sq. ft.	1 Pallet	3 Pallets
19*	20.63 ft.	334.37 sq. ft.	1 Pallet	3 Pallets + 3 Bands
20	21.69 ft.	369.55 sq. ft.	1 Pallet	3 Pallets + 6 Bands

**\*Example: To build a 20.63' dia. circle, you'll need (1) starter kit + (1) large circle pallet + (3) 3/4 sq. pallets + (3) 3/4 sq. bands.**

Dimensions shown are nominal. Pallet square footage is accurate, layers and bands square footages have been rounded to nearest whole number.

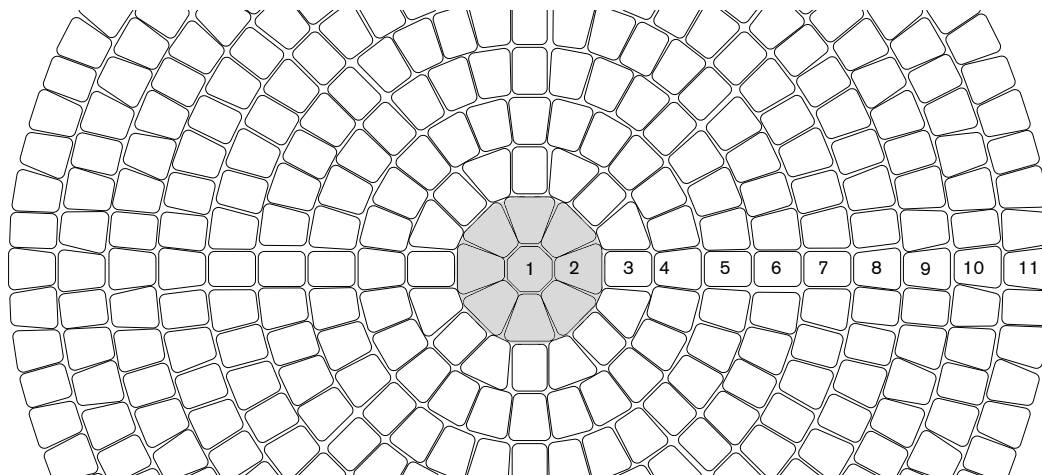

# American Brick Paver 6cm

Interlock Concrete Products

## Features

- One piece paver, ideal for borders, accents and insets
- Subtle texture surfaces
- Radius edges and corners
- No spacers, zero joint



All colors protected with KolorLast

Available by layer.

## Colors

- Tuscan Red w/KolorLast
- Brown w/KolorLast
- Buff w/KolorLast
- Onyx w/KolorLast



Use roller compactor or buffer pad when compacting.

Size	Face Area	Weight	Units/Layer	Layer	Layers	Units/Pallet	Pallet Weight
8 x 2.5 x 2.375" H	0.14 sq. ft.	3 lbs.	60	8.4 sq. ft.	10	600 (84 sq. ft.)	1,800 lbs.

Dimensions shown are nominal. Pallet square footage is accurate, layers and bands square footages have been rounded to nearest whole number

# Lamont Paver 6cm

Interlock Concrete Products



## Features

- Four separate sizes, smooth surface, tumbled system
- No auto spacers, zero joint
- Suitable for vehicular applications
- Extremely versatile – endless designs
- Circle kits available

Available by pallet or band.

## Colors

- Antique Brown
- Beechwood
- Sierra Gray
- Santa Fe

## 4 x 8 and 6 x 8 Accent Colors

- Brown
- Desert Buff
- Onyx



Name	Size	Face Area	Weight	Units/Band	Bands/Pallet	Units/Pallet	Pallet Weight
4 x 8	4.13 x 8.25 x 2.375" H	0.24 sq. ft.	7 lbs.	80 (19.2 sq. ft.)	5	400 (96 sq. ft.)	2,625 lbs.
6 x 8	6.1875 x 8.25 x 2.375" H	0.35 sq. ft.	10 lbs.	50 (17.8 sq. ft.)	5	250 (89 sq. ft.)	2,450 lbs.
10 x 8	10.3 x 8.25 x 2.375" H	0.59 sq. ft.	17 lbs.	40 (23.75 sq. ft.)	4	160 (95 sq. ft.)	2,710 lbs.
12 x 8	12.375 x 8.25 x 2.375" H	0.71 sq. ft.	21 lbs.	40 (28.5 sq. ft.)	4	160 (114 sq. ft.)	3,170 lbs.

Dimensions shown are nominal. Pallet square footage is accurate, layers and bands square footages have been rounded to nearest whole number.

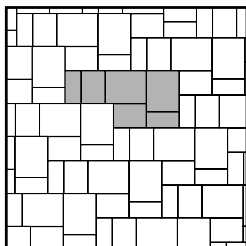

**Pattern 1**  
4 x 8 = 20%  
6 x 8 = 30%  
10 x 8 = 50%

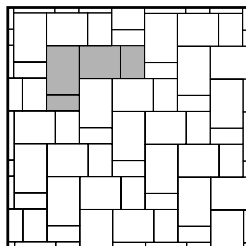

**Pattern 2**  
4 x 8 = 12%  
6 x 8 = 19%  
10 x 8 = 31%  
12 x 8 = 38%

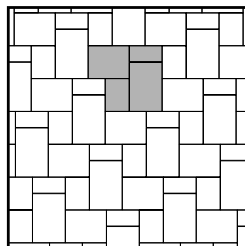

**Pattern 3**  
4 x 8 = 12%  
6 x 8 = 19%  
10 x 8 = 31%  
12 x 8 = 38%

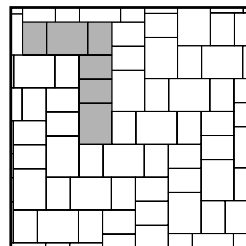

**Pattern 4**  
6 x 8 = 45%  
10 x 8 = 55%

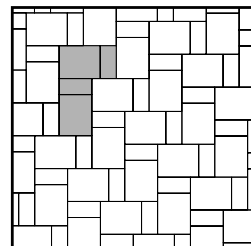

**Pattern 5**  
4 x 8 = 29%  
10 x 8 = 71%



# Lamont Circle 6cm

Interlock Concrete Products



## Circle Kit Pallet

- Makes 7 course, 10.33 ft. dia. circle
- No auto spacers, zero joint
- Use 6 x 8 units for addn'l courses

## Colors

- Antique Brown
- Beechwood
- Santa Fe
- Sierra Gray

Circle Kit Pallet (10.33 ft. dia.)	Size	Face Area	Weight Ea.	Units/Pallet	Pallet	Pallet Weight
Center	8.26 x 8.26 x 2.375" H	0.47 sq. ft.	13 lbs.	9 (8 extra)	-	-
Small Circle	9.39 x 8.26 x 2.375" H	0.54 sq. ft.	15 lbs.	9	-	-
Middle Circle	7.97 x 8.26 x 2.375" H	0.59 sq. ft.	17 lbs.	18	89 sq. ft.	2,520 lbs.
Large Circle	7.21 x 8.26 x 2.375" H	0.41 sq. ft.	12 lbs.	135	-	-
6 x 8	6.187 x 8.26 x 2.375" H	0.35 sq. ft.	10 lbs.	81	-	-

## CIRCLE KIT PALLET

Course	Outside Dia.	Outside Dia. (ft.)	Area (sq. ft.)	Center	Small Circle	Middle Circle	Large Circle	6 x 8
Center	8.26"	0.69	0.37	1	-	-	-	-
1	24.76"	2.06	3.34	-	8	-	-	-
2	41.26"	3.44	9.29	-	-	16	-	-
3	57.76"	4.81	18.20	-	-	-	24	-
4	74.26"	6.19	30.08	-	-	-	32	-
5	90.76"	7.56	44.93	-	-	-	20	20
6	107.26"	8.94	62.75	-	-	-	24	24
7	123.76"	10.33	83.54	-	-	-	28	29

## ADDITIONAL COURSES (6 x 8's only)

8	140.11"	11.68	107.07	-	-	-	-	72 (2 Bands)
9	156.46"	13.04	133.52	-	-	-	-	80 (3 Bands)
10	172.81"	14.40	162.88	-	-	-	-	88 (1 Pallet)
11	189.16"	15.76	195.16	-	-	-	-	97 (1 Pallet + 2 Bands)
12	205.51"	17.13	230.35	-	-	-	-	105 (1 Pallet + 4 Bands)
13	221.86"	18.49	268.46	-	-	-	-	113 (2 Pallets + 1 Bands)
14	238.21"	19.85	309.49	-	-	-	-	122 (2 Pallets + 4 Bands)
15*	254.56"	21.21	353.43	-	-	-	-	130 (3 Pallets + 2 Bands)

**\*Example: To build a 21.2' dia. circle, you'll need (1) Circle Kit pallet + (3) 6 x 8 pallets + (2) 6 x 8 bands**

Dimensions shown are nominal. Pallet square footage is accurate, layers and bands square footages have been rounded to nearest whole number.

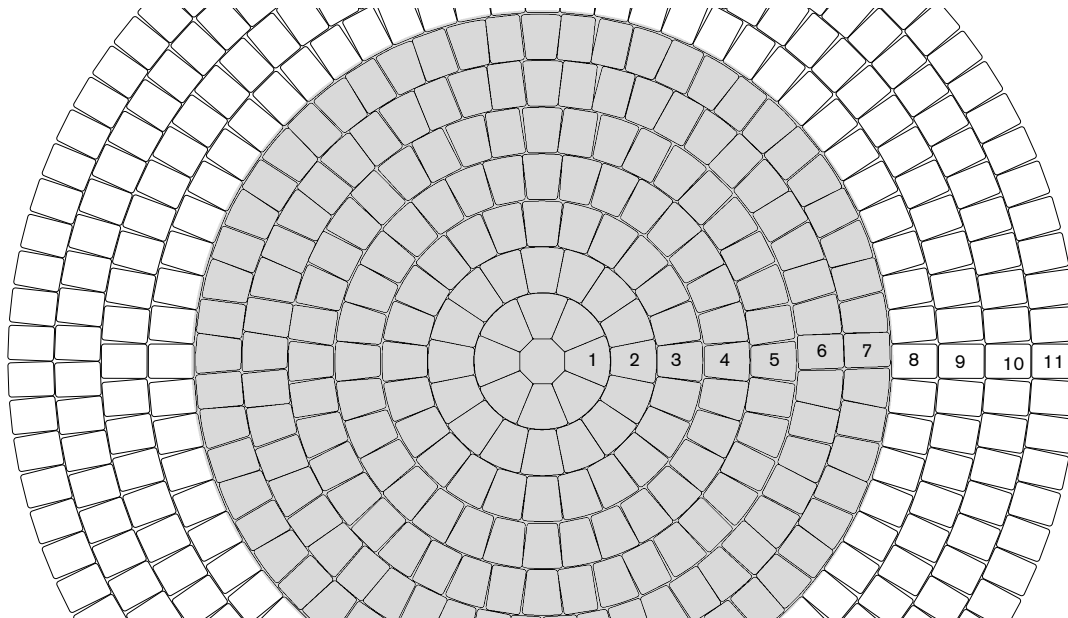



# Cobble Stone Paver 8cm

Interlock Concrete Products

## Features

- Four-piece, one-pallet system
- Designed for driveways, pathways and accenting applications
- Subtle texture top with soft edge detail
- Lays in a running bond
- Large auto-spacer; high flow rate eco/permeable

Available by pallet or layer.

## Colors

- Beechwood
- Moonlight Gray
- Onyx w/KolorLast



Use roller compactor or buffer pad when compacting.

Size	Face Area	Units/Layer	Layer	Layers	Units/Pallet	Pallet Weight
7.125 x 5.875 x 3.125" H	0.29 sq. ft.	8	(Sold as sets)			
8.625 x 5.875 x 3.125" H	0.36 sq. ft.	8	12.33 sq. ft.	6	192 (74 sq. ft.)	2,575 lb
10.375 x 5.875 x 3.125" H	0.42 sq. ft.	8				
11.875 x 5.875 x 3.125" H	0.48 sq. ft.	8				

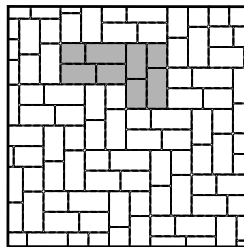
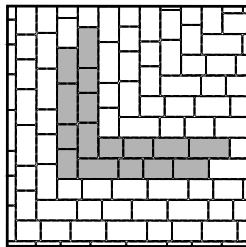
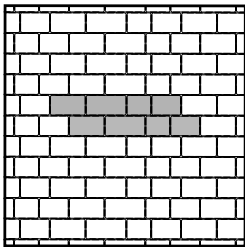

# Flagstone Paver 6cm

Interlock Concrete Products

## Features

- One shape, six unique slate embossed faces
- 2.375" H, 1.58 sq. ft. each
- Deep/wide false joint
- Simple running bond installation
- Suitable for pedestrian applications

## Colors

- Antique Brown
- Sierra Gray
- Santa Fe



Use roller compactor or buffer pad when compacting.

Available by pallet or layer.

Size	Face Area	Weight	Units/Layer	Layer	Layers	Units/Pallet	Pallet Weight
Six Faces	1.58 sq. ft.	45.8 lbs.	6	9.5 sq. ft.	10	60 (95 sq. ft.)	2,806 lbs.

Dimensions shown are nominal. Pallet square footage is accurate, layers and bands square footages have been rounded to nearest whole number.

# 6 x 12 Accent Pavers 6cm

Interlock Concrete Products

## Features

- Chamfered/irregular edge
- Auto spacers, 1/8" joint
- Suitable for vehicular applications

## Colors

- Brown w/KolorLast
- Buff w/KolorLast
- Onyx w/KolorLast
- Natural (smooth only)



Smooth or Slate Top

Available by pallet or layer.

Size/Name	Dimensions	Area (ea.)	Weight (ea.)	Units/layer	Area/layer	Layers	Units/pallet	Weight/pallet
6 x 12	5.75 x 11.5 x 2.375" H	0.46 sq. ft.	13 lbs.	21	9.66 sq. ft.	10	210 (97 sq. ft.)	2,780 lbs.

# Holland Pavers 6cm & 8cm

Interlock Concrete Products

## Features

- Larger than typical Hollands (4.25" W x 8.5" H)
- Smooth top, beveled edge
- Small auto-spacer
- For patios, paths, pools and drives
- Endless design opportunities

Available by pallet or band.



## 6cm Colors

- Antique Copper
- Beechwood
- Brown
- Buff
- Moonlight Gray
- Onyx w/KolorLast
- Rosewood
- Natural (NEW)

(8cm is special order)

8cm Holland pavers can be made in any color. Minimum quantity required, customer must take entire production run. Returns not allowed. Available with KolorLast (addn'l charge).

Size	Face Area	Weight	Units/Bands	Bands	Band	Units/Pallet	Pallet
8.5 x 4.25 x 2.375" H	0.24 sq. ft.	7 lbs.	80	5	19.6 sq. ft.	400 (98 sq. ft.)	2,785 lbs.
8.5 x 4.25 x 3.125" H	0.24 sq. ft.	9 lbs.	56	5	13.8 sq. ft.	280 (69 sq. ft.)	2,560 lbs..

Dimensions shown are nominal. Pallet square footage is accurate, layers and bands square footages have been rounded to nearest whole number.

# Holland-Eco Paver 8cm

Interlock Concrete Products

## Features

- 5" x 10" and 5" x 5" (x 3.125" H) (can be ordered without squares)
- Large auto-spacer; high flow rate eco/permeable
- Ideal for vehicular applications
- Machine layable

Available by pallet.

## Colors

- Beechwood
- Carmel



Size	Face Area	Weight	Units/Layer	Layers	Units/Pallet	Pallet Weight
4.875 x 9.75 x 3.125" H	0.34 sq. ft.	13 lbs.	28 (10.6 sq. ft.)	8	224 (84.7 sq. ft.)	3,050 lbs.
4.875 x 4.875 x 3.125" H	0.17 sq. ft.	6.54 lbs.	7	-	-	-

Dimensions shown are nominal. Pallet square footage is accurate, layers and bands square footages have been rounded to nearest whole number.

# Turfstone-Eco Paver 8cm (special order)

Interlock Concrete Products

## Features

- High flow rate permeable (Voids = 0.25 cu. ft. per unit)
- Special order – set-up fee and minimum quantities apply

Can be made in any color. Minimum quantity required, customer must take entire production run. Returns not allowed.



Size	Face Area	Weight	Units/Band	Band	Bands	Units/Pallet	Pallet Weight
23.63 x 15.75 x 3.125" H	2.58 sq. ft.	64.5 lbs.	16	41 sq. ft.	2	32 (82 sq. ft.)	1,940 lbs.

Dimensions shown are nominal. Pallet square footage is accurate, layers and bands square footages have been rounded to nearest whole number.

# Accenting and Border Pavers

With the exception of Broadmour 10cm and Cobble Stone 8cm pavers, all our other pavers are 6cm in height – making them extremely design and install friendly. The endless combinations of all our paver shapes, colors and textures give designers complete freedom to make their hardscape designs truly exceptional.

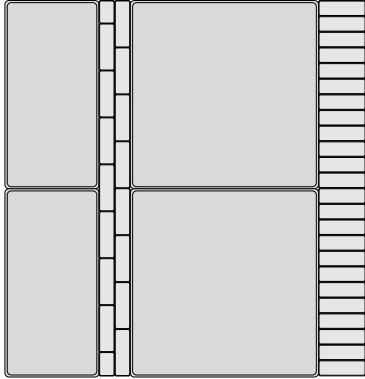

## American Brick Paver: Brown, Buff, Onyx and Tuscan Red (all KolorLast)



Basket



Double Sailor

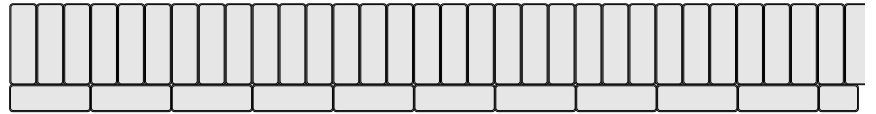

Soldier with Sailor

## 6 x 12 Accent Pavers: Brown, Buff and Onyx (all KolorLast)

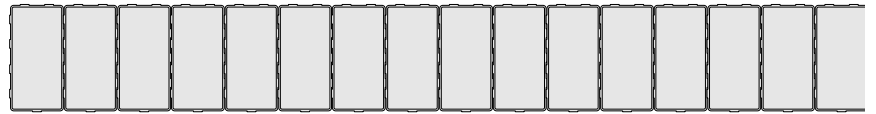
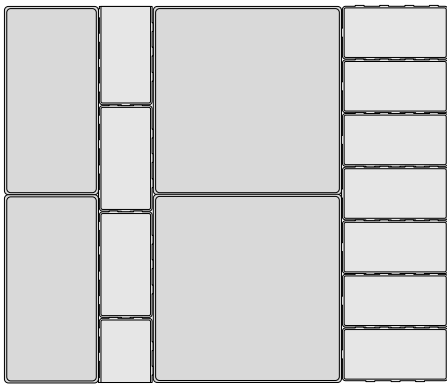

Soldier Course



Double Sailor

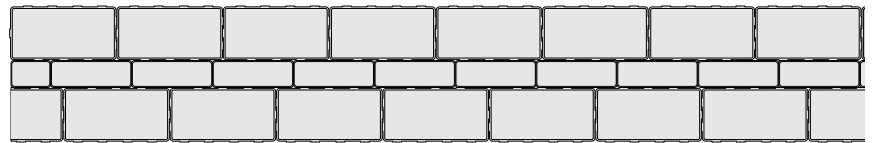

Double Sailor with American Brick

## Colonial Accent: Brown, Buff and Onyx w/KolorLast

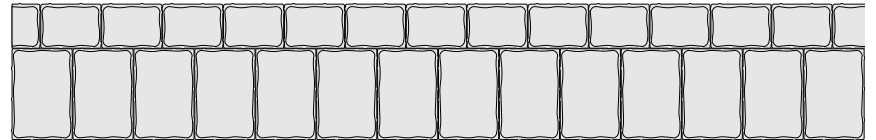
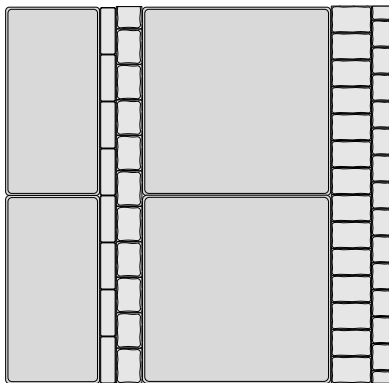

3/4 Square Sailor with 6 x 9 Soldier



6 x 9 Sailor with American Brick Sailor



3/4 Square Sailor with American Brick Sailor



3/4 Square Soldier with American Brick Sailor

Examples shown to scale with a 24" pavers.

**Lamont 4 x 8 and 6 x 8: Brown, Desert Buff and Onyx**

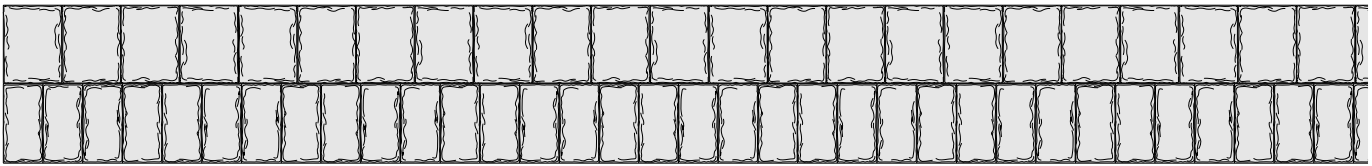

4 x 8 and 6 x 8 Soldier Courses

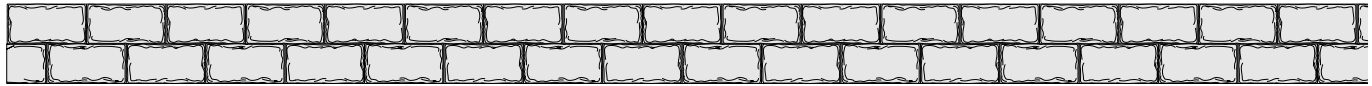

4 x 8 Double Sailor Course



4 x 8 Double Sailor with American Brick

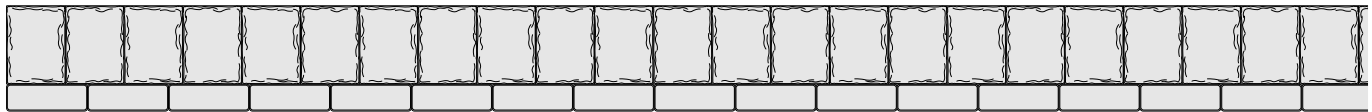

6 x 8 Soldier with American Brick Sailor Course

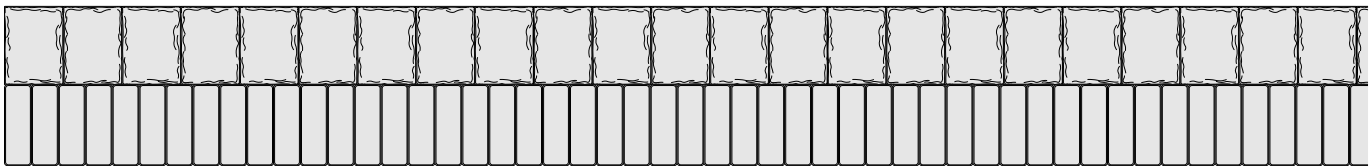

6 x 8 Soldier with American Brick

**Flagstone:**

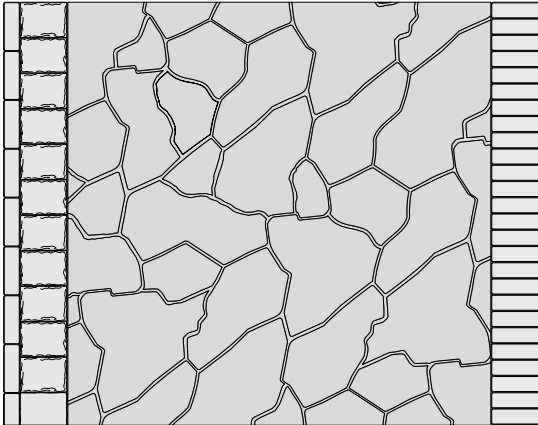

6 x 8 Lamont Soldier with American Brick Sailor Course

American Brick Soldier

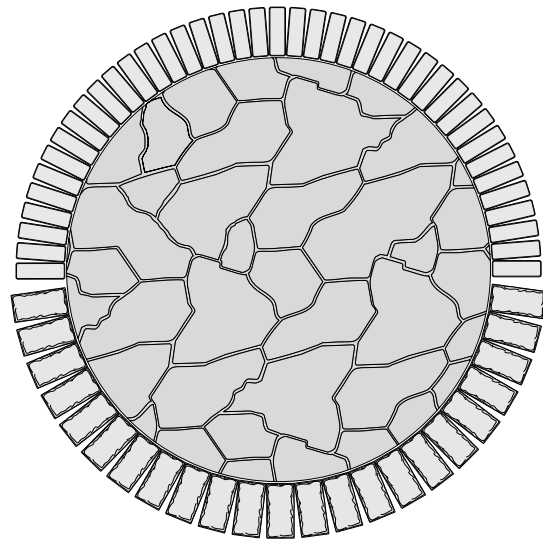

Flagstone Inlay with American Brick and 6 x 12 Accent

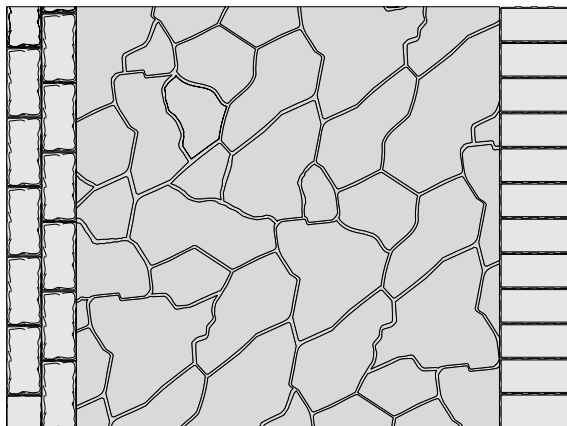

4 x 8 Lamont Double Sailor Course

6 x 12 Accent Soldier Course



# Porcelain Tiles 2cm

Xteriors from Daltile

Porcelain pavers offer on-trend outdoor design in durable and long-lasting wood-look porcelain or stone. The 2 centimeter thickness ensures that your outdoor spaces from the patio & pool to the driveway & garage will turn heads no matter your climate. Consider Xteriors for your pool, patio, and outdoor kitchen for an experience that rivals the comforts and high design of the indoors. Expand your design horizons by using Xteriors products for rooftops, driveways, and elevated decks.

NAME	APPEARANCE	SHAPE	SIZE (ACTUAL DIMENSIONS)	THICKNESS	PACKAGING
Ambassador™	Lineal Quartzite	Rectangle	16 x 48 (15-9/16" x 47")	13/16" (2cm)	5.16 sq. ft., 1/carton
Assemble™	Agglomerate Stone	Square	32 x 32 (31-5/16" x 31-5/16")	13/16" (2cm)	6.89 sq. ft., 1/carton
Commissary™	Wood	Rectangle & Square**	16 x 48 (15-9/16" x 47")	13/16" (2cm)	5.16 sq. ft., 1/carton
Delegate™	Compressed Slate	Rectangle	20 x 40 (19-1/2" x 39-3/16")	13/16" (2cm)	5.38 sq. ft., 1/ carton
Dignitary™	French Limestone	Square	24 x 24 (23-7/16" x 23-7/16")	13/16" (2cm)	7.76 sq. ft., 2/carton
Diplomacy™	Belgian Bluestone	Square	24 x 24 (23-7/16" x 23-7/16")	13/16" (2cm)	7.76 sq. ft., 2/carton
Diplomacy™	Belgian Bluestone	Rectangle	20 x 40 (19-1/2" x 39-3/16")	13/16" (2cm)	5.38 sq. ft., 1/carton

\*\* Deputy Grey and Regent Honey colors also available in 24" x 24"

## TIMELESS STYLE, SUPERIOR DURABILITY – HERE’S HOW 2CM PORCELAIN PAVERS STACK UP AGAINST OTHER PRODUCTS ON THE MARKET.

	PORCELAIN PAVERS	CLAY BRICK PAVERS	CAST IN PLACE	CONCRETE PAVERS	NATURAL STONE
Stain Resistance	HIGH	Medium	Low	Low	Low
UV Resistance	WILL NOT FADE	High	Low	Low	High
Scratch Resistance	HIGH	Medium	Low	Low	Low
Freeze Thaw Resistance	FREEZE THAW PROOF	Medium	Low	Low	Low
De-Icing Salt Resistance	HIGH	Medium	Low	Low	Low
Acid Resistance	HIGH	Low	Low	Low	Low
Water Absorption (ASTM #373)	< 0.5%	< 8%	< 10%	< 5%	< 5%
Sealing	NEVER	No	Recommended	Recommended	Recommended
Compressive Strength (Psi)	>30,000	>8,000?	>2,500 (residential) >4,000 (commercial)	>8,000	1,800-19,000*
Weight (lbs/sf)	9	21 - 31	12.5	27 - 36	15-50*

\*Varies by stone.

[www.daltile.com/xteriors](http://www.daltile.com/xteriors)

## APPLICATIONS

	Target DCOF Wet	Suitable
Dry & Level – Interior Floor	N/A	✓
Wet & Level – Interior Floor	≥ 0.42	✓
Shower Floors (Residential or Light Commercial)	≥ 0.42	✓
Exterior Floor Applications (including pool decking & other wet areas with minimal footwear)	≥ 0.60	✓
Ramps & Inclines	≥ 0.65	-
Walls/Backsplashes	N/A	✓
Countertops	N/A	✓
Pool Linings	N/A	-

A DCOF value of ≥0.42 is the standard for tiles specified for level interior spaces expected to be walked upon when wet, as stated in ANSI A137.1-A326.3. For more information about DCOF and the DCOF AcuTest™, visit [daltille.com/DCOF](http://daltille.com/DCOF).

**APPLICATION NOTES:** Suitable for exterior applications in freezing and non-freezing climates, when proper installation methods are followed.

**NOTES:** Since there are variations in all fired ceramic and natural products, tile and trim supplied for your particular installation may not match samples. Final confirmation should be made from actual tiles and trim prior to installation. Manufactured in accordance with ANSI A137.1 standards.

For additional information refer to "Factors to Consider" at: [daltille.com/Factors](http://daltille.com/Factors).

Random visuals enhance the natural beauty of this product. To achieve optimal results, all tile should be selected from multiple cartons and shading and graphic arrangement planned prior to installation.

## PERFORMANCE CHARACTERISTICS

	ASTM#	Paver Result
Water Absorption	C373	< 0.5%
Breaking Strength	C648	> 1000 lbs
Scratch Hardness	MOHS	8.0
Chemical Resistance	C650	Resistant
Abrasion Resistance	C1027	N/A

For addition on test results, visit us at: [daltille.com/information/TestResults](http://daltille.com/information/TestResults).

## STYLE, SIZE & COLOR

### AMBASSADOR (Stone Look)

Inspired by fine-grained quartzite found in the Swiss Alps, the Ambassador series lends high-end styling wherever it's used. Eons of stratification are reflected in the distinctive mono-directional graining and make the series a natural choice for commercial and residential spaces. Size: 16" x 48". Colors: Jet Setter Dusk and Voyager Black.

### ASSEMBLE (Stone Look)

Terrazzo and agglomerated stone look porcelain come together to create the perfect design. This collection is comprised of stone looks that construct unique visuals. Assemble provides a contemporary and modern expression to your outdoor space. Size: 32 x 32". Colors: Emissary, Magistrate and Proxy.

### COMMISSARY (Wood Look)

These porcelain pavers combine style and performance with unsurpassed durability. Bring the beauty of the finest natural looking wood to your outdoor living environment. As rich and natural as the inspiration from which it was created, our outdoor pavers offer design solutions with character, strength and a sophisticated contemporary appeal for any project. Size: 16" x 48". Colors: Bureau Brown, Commander Beige, Proxy Grey, (Deputy Grey and Regent Honey also available in 24" x 24").

### DELEGATE (Stone Look)

This sedimentary slate-inspired design offers a rich visual with depth and interest. The diagonal visual on this ColorBody™ porcelain tile is the subtle evidence of nature's powerful geological movements. Gentle color movement in the white and grey shades offers a slight visual distinction from the darker, monochromatic black hue. Size: 20" x 40". Colors: Dark Grey and Light Grey.

### DIGNITARY (Stone Look)

The imaginative Dignitary Series provides depth on surfaces as it replicates French limestone embedded with fossil layers and natural veins. Beautiful as it is strong, this outstanding paver tile is equally suited to traditional or contemporary styles, bringing ageless dimension to any outdoor application. Size: 24" x 24". Colors: Luminary White, Notable Beige and Superior Taupe.

### DIPLOMACY (Stone Look)

Diplomacy deftly delivers the quiet strength and visual beauty of quarried Belgian bluestone. Available in authentic stone look smoky hues that come alive with movement created by delicate highlights of light greys and whites. 24" x 24" and Size: 20" x 40". Colors: Dark Grey and Light Grey.

## INSTALLATION

### Dry Laying on Grass:

The gaps between the slabs should be chosen depending on the overall desired aesthetic.

### Dry Laying on Gravel:

Gaps of at least 3/16" (5 mm) should be left between slabs, using spacers to set the correct width. Joint may be left empty or filled with fine sand, polymeric sand specifically formulated for porcelain tile or small, clean aggregate, depending on the joint width and desired aesthetic.

### Dry Laying on Sand:

The gaps between the slabs should be chosen depending on the overall desired aesthetic.

### Laying on Screed with Adhesive:

Slabs must be laid with open joints of variable width of no less than 3/16" (5 mm).

### Raised Pavings:

Pedestal contains correct tile spacers for application.



ALL-WEATHER SOLUTIONS FOR EXTERIOR STYLE

BY  daltille

# Vintage 6 Wall

Rockwood Retaining Walls

## Features

- Three-piece system, all sizes on one pallet
- Split-faced, tumbled vertical wall system with anchor bar connection
- Builds straight or 8' radius without cutting, freestanding or retaining walls
- End blocks are split on three sides, corner/pillar block split on two sides

Available in broken pallets.

## Colors

- Beechwood
- Bluestone
- Cascade (**NEW**)
- Santa Fe



**Non-tumbled  
(split-face)  
Avail. Spring 2021**

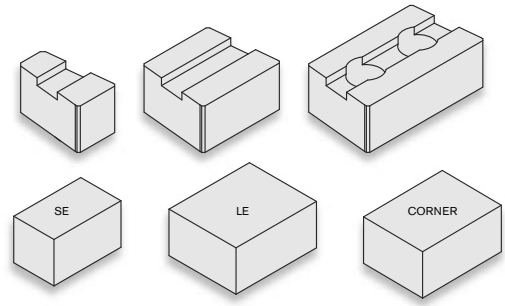

Vintage 6	Size	Face Area	Weight	Pallets	Weight
Small (S)	6 x 10 x 6" H	0.25 sq. ft.			
Medium (M) sold as sets, full pallets only	12 x 10 x 6" H	0.50 sq. ft.	137.5 lbs.	20 sets (30 sq. ft.)	2,790 lbs.
Large (L)	18 x 10 x 6" H	0.75 sq. ft.			
Small End block (SE) sold in sets	6 x 10 x 6" H	0.42 sq. ft.			
Large End block (LE)	12 x 10 x 6" H	0.83 sq. ft.	81.50 lbs.	8 sets (10 sq. ft.)	702 lbs.
Corner/Pillar Block (Full pallets only)	12 x 9 x 6" H	0.50 sq. ft.	48 lbs.	30 (15 sq. ft.)	1,490 lbs.

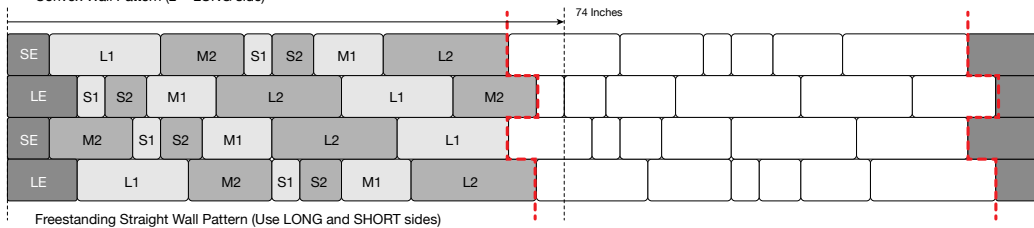
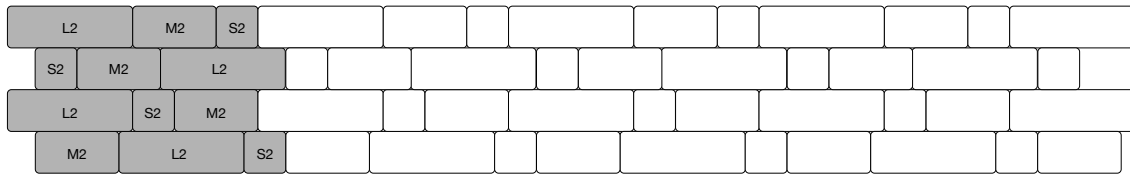
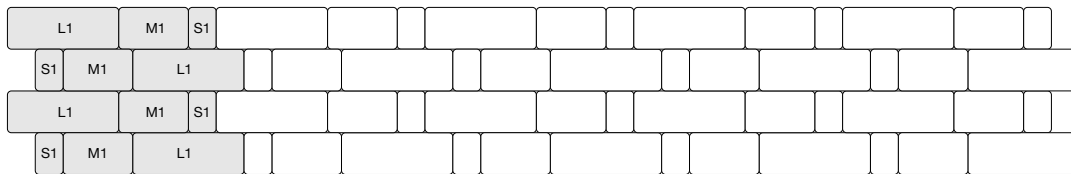

# Riverland Wall

Rockwood Retaining Walls



## Features

- Three-piece, tumbled, one-pallet system
- Builds 7'-8" radius without cutting
- Cap with 3" or Chiseled Cap

Available by pallet.

## Colors

- Beechwood
- Bluestone
- Cascade
- Santa Fe
- Onyx

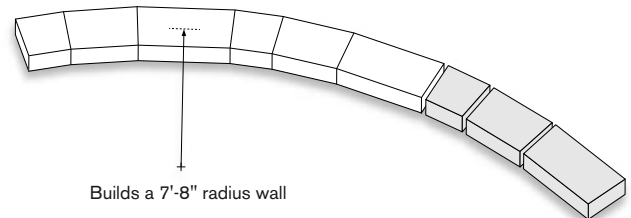

Block	Size	Face Area	Weight	Layers	Sets/Layer	Sets/Pallet	Pallet Weight
Small	8 x 8 x 4" H	(3 piece sets)					
Medium	12 x 8 x 4" H	1.0 sq. ft.	90 lbs.	6	5	30 (30 sq. ft.)	2,750 lbs.
Large	16 x 8 x 4" H						



# Lakeland Wall

Rockwood Retaining Walls

**ROCKWOOD**<sup>®</sup>  
RETAINING WALLS  
*A better way.™*

## Features

- Tumbled, three-piece, two-pallet system builds vertical, freestanding garden/retaining walls, planters, seatwalls and outdoor living features
- Builds straight walls
- Cap with 3" or Chiseled Cap

Available by pallet.

## Colors

- Beechwood
- Bluestone
- Cascade
- Santa Fe
- Onyx (also available non-tumbled, large only)

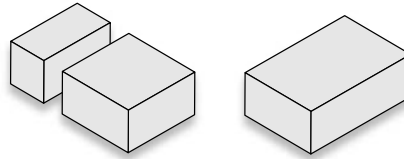

Lakeland II (sets)

Lakeland (standard)

Block	Size	Face Area	Weight	Layers	Units/Pallet	Weight
Small (Lakeland II)	4 x 8 x 4" H	(2 piece sets)	31 lbs.	4 (20 sets)	80 sets (26 sq. ft.)	2,530 lbs.
Medium	8 x 8 x 4" H	0.33 sq. ft.				
Large (Std.)	12 x 8 x 4" H	0.33 sq. ft.	31 lbs.	4 (20 units)	80 (26 sq. ft.)	2,530 lbs.

To estimate number of units, divide total sq. ft. by 0.33.

# Contemporary Wall

Rockwood Retaining Walls



## Features

- Three-piece, one-pallet system
- Builds vertical, freestanding garden/retaining walls, planters, seatwalls and outdoor living features

Available by pallet.

## Colors

- Beechwood
- Cascade
- Onyx

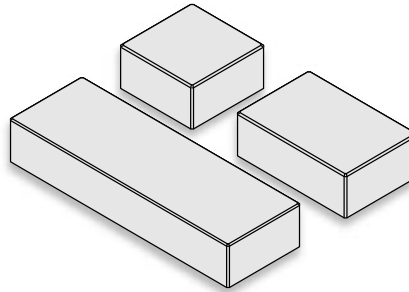

Block	Size	Face Area	Weight	Layers	Units/Pallet	Weight
Small	8 x 8 x 4" H	(3 piece sets)	122 lbs./set	4	20 sets (26.6 sq. ft.)	2,480 lbs.
Medium	16 x 8 x 4" H	1.33 sq. ft./set				
Large	24 x 8 x 4" H	0.33 sq. ft.	31 lbs.	4 (20 units)	80 (26.6 sq. ft.)	2,530 lbs.

**ROCKWOOD**<sup>®</sup>  
RETAINING WALLS  
*A better way.™*

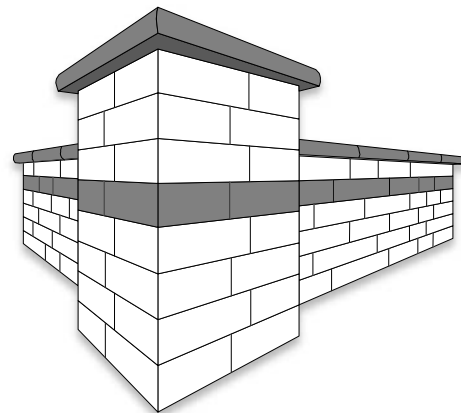

# Classic® 6 and 8 Walls

Rockwood Retaining Walls



## Features

- Straight and beveled face options
- Strong and versatile, efficient to build, one-unit system
- Matching half and corner block (2-3 day lead time req.)
- Cap with 4" Universal or Chiseled Cap

Available by layer or pallet.

## Classic 6 Colors (1.0" setback, adjustable),

- Bluestone (straight or beveled face)
- Sandstone Brown (straight or beveled face)
- Santa Fe (straight or beveled face)

- Charcoal (straight face)
- Gray (straight face)
- Sandstone (straight face)

## Classic 8 Colors (1.0" setback, adjustable)

- Gray (straight or beveled face)
- Sandstone (straight or beveled face)
- Brown (straight face)
- Sandstone Brown (straight face)
- Base block in gray only (straight face)

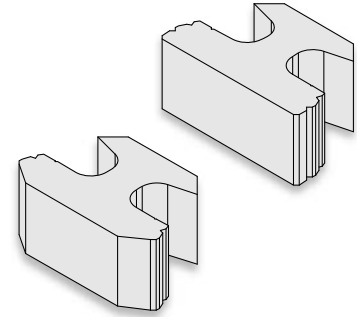

Classic 6	Size	Face Area	Weight	Units/Layer	Layers	Units/Pallet	Pallet Weight
Straight Face	18 x 12 x 6" H	0.75 sq. ft.	64 lbs.	12	3	36 (27 sq. ft.)	2,354 lbs.
Straight Base	18 x 12 x 6" H	0.75 sq. ft.	64 lbs.	12	3	36 (27 sq. ft.)	2,354 lbs.
Beveled Face	18 x 12 x 6" H	0.75 sq. ft.	60 lbs.	12	3	36 (27 sq. ft.)	2,210 lbs.
Half Block	9 x 12 x 6" H	0.38 sq. ft.	30 lbs.	12	1	12 (4.56 sq. ft.)	410 lbs.
Corner Block	13 x 5.5 x 6" H	0.54 sq. ft.	32 lbs.	12	1	12 (6.48 sq. ft.)	434 lbs.

To estimate number of units, divide total sq. ft. by 0.75 for Classic 6.

Classic 8	Size	Face Area	Weight	Units/Layer	Layers	Units/Pallet	Pallet Weight
Straight Face	18 x 12 x 8" H	1.0 sq. ft.	85 lbs.	12	2	24 (24 sq. ft.)	2,090 lbs.
Straight Base (gray only)	18 x 12 x 8" H	1.0 sq. ft.	85 lbs.	12	2	24 (24 sq. ft.)	2,090 lbs.
Beveled Face	18 x 12 x 8" H	1.0 sq. ft.	79 lbs.	12	2	24 (24 sq. ft.)	1,946 lbs.
Half Block	9 x 12 x 8" H	0.5 sq. ft.	39 lbs.	12	1	12 (6 sq. ft.)	518 lbs.
Solid Corner Block**	18 x 9 x 8" H	1.0 sq. ft.	100 lbs.	5	4	20 (20 sq. ft.)	2,050 lbs.

Corners are split on one long and one short side. \*\* Rochester and Beaver Dam only.

# Classic® 8 DOT Wall Block and Caps

Rockwood Retaining Walls

- 1" setback, adjustable
- Straight face in Sandstone or Gray
- Beveled face (special order)

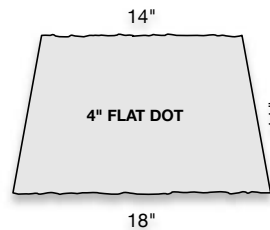
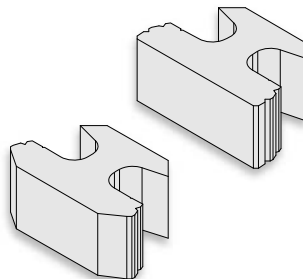

Split face front/back.  
Spec'd in WI.

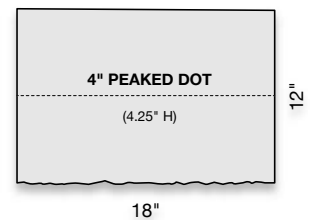

Split face front.  
Spec'd in MN and IA.

Classic 8 DOT	Size	Face Area	Weight	Units/Layer	Layers	Units/Pallet	Pallet Weight
Straight Face	18 x 12 x 8" H	1.0 sq. ft.	87 lbs.	12	2	24 (24 sq. ft.)	2,130 lbs.
Beveled Face*	18 x 12 x 8" H	1.0 sq. ft.	82 lbs.	12	2	24 (24 sq. ft.)	2,018 lbs.
4" Flat Cap	18 W x 11 x 4" H (Front) 14 W x 11 x 4" H (Back)	1.0 ln. ft.	55 lbs.	9	5	45 (60 ln. ft.)	2,520 lbs.
4" Peaked Cap	18 W x 12 x 4" H	1.5 ln. ft.	70 lbs.	8	4	32 (48 ln. ft.)	2,290 lbs.

# Classic Colonial® 6 Wall

Rockwood Retaining Walls

**ROCKWOOD®**  
RETAINING WALLS  
*A better way.™*

## Features

- Multi-unit appearance, rustic face
- A strong and versatile, efficient to build, one-unit system
- Matching base, corner and half blocks (2-3 day lead time req.)
- Cap with 4" Universal or Chiseled Cap
- 1.0" setback, adjustable

## Classic Colonial 6

- Available by layer or pallet
- Bluestone
- Santa Fe
- Sandstone Brown

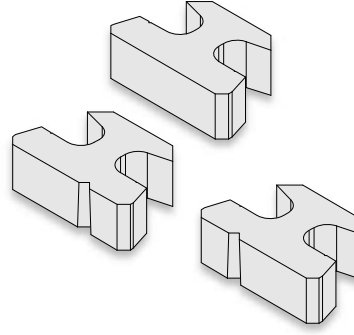

Classic Colonial 6	Size	Face Area	Weight	Units/Layer	Layers	Units/Pallet	Pallet Weight
Colonial 18	18 x 12 x 6" H	0.75 sq. ft.	60 lbs.	12	3	36 (27 sq. ft.)	2,260 lbs.
Colonial 6/12	18 x 12 x 6" H	0.75 sq. ft.	60 lbs.	12	3	36 (27 sq. ft.)	2,260 lbs.
Base Block	18 x 12 x 6" H	0.75 sq. ft.	60 lbs.	12	3	36 (27 sq. ft.)	2,260 lbs.
Half Block	9 x 12 x 6" H	0.38 sq. ft.	30 lbs.	12	1	12 (4.56 sq. ft.)	410 lbs.
Corner Block	13 x 5.5 x 6" H	0.54 sq. ft.	32 lbs.	12	1	12 (6.48 sq. ft.)	434 lbs.

Colonial 6/12 and 18 palletized separately. To estimate number of Classic Colonial 6 units, divide total sq. ft. by 0.75.

# Classic Colonial® 8 Wall (special order)

Rockwood Retaining Walls

- Multi-unit appearance, rustic face
- 1.0" setback, adjustable
- Special order, can be made in any color

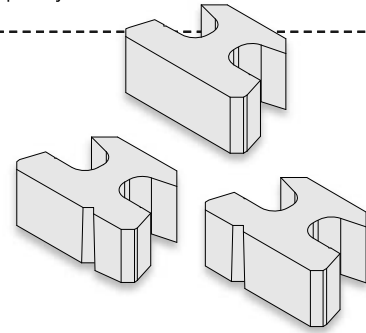

Classic Colonial 8*	Size	Face Area	Weight	Units/Layer	Layers	Units/Pallet	Pallet Weight
Colonial 18	18 x 12 x 8" H	1.0 sq. ft.	85 lbs.	12	2	24 (24 sq. ft.)	2,090 lbs.
Colonial 6/12	18 x 12 x 8" H	1.0 sq. ft.	85 lbs.	12	2	24 (24 sq. ft.)	2,090 lbs.
Base Block (gray only)	18 x 12 x 8" H	1.0 sq. ft.	85 lbs.	12	2	24 (24 sq. ft.)	2,090 lbs.
Half Block	9 x 12 x 8" H	0.50 sq. ft.	39 lbs.	12	1	12 (6 sq. ft.)	518 lbs.
Corner Block	13 x 5.5 x 8" H	0.72 sq. ft.	40 lbs.	12	1	12 (8.64 sq. ft.)	530 lbs.

\* Set-up fee and minimum quantity required, customer must take entire production run. Returns not allowed.

## The Advantages of the Classic® System...

### It's Fast...

Located on the underside of each Classic® block, the 4" x 2" Anchor Bar creates an automatic setback with the highest shear resistance in the industry. Plus, Classic's fewer pieces, pinless design, and lower weight per square foot reduces construction time, labor costs, and freight charges.

### It's Simple...

"One Unit" construction is a vital element of Classic's superior design. 90° corners and half blocks are made simply by removing a portion of the block. No special blocks are required; no special inventories are needed; no shortages occur on the jobsite!

### It's Strong...

Upon assembly, Classic blocks automatically create 4" x 5" vertical "stone columns". When layered with grid, the gravel filled "stone columns" provide a multi-point interlock, for a more uniform block-to-grid connection.

### It's Versatile...

Variable setbacks, sharp radius turns, "One Unit" construction, and complete interchangeability are all features of Rockwood's Classic System. The ability to mix various sizes and colors within a wall enhances your imagination without sacrificing structural integrity. Plus, the Anchor Bar allows you to build at any setback you desire - from 0° to 14°, providing the only "true" vertical setback in the industry.

*Appearance  
Dependability  
Efficiency*

**ROCKWOOD®**  
RETAINING WALLS  
*A better way.™*

### Install manuals:

<http://rockwoodwalls.com/installation>

# StoneHedge 6 Wall (special order)

Rockwood Retaining Walls

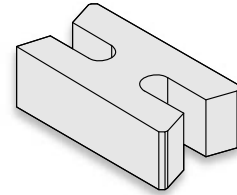

## Features

- Split face front and back
- Vertical system, integrates with Classic blocks
- Creates seatwalls, enclosures and privacy walls
- Special order, can be made in any color

Can be made in any color. Minimum quantity required, customer must take entire production run. Returns not allowed.

Block	Size	Face Area	Weight	Units/Layer	Layers	Units/Pallet	Pallet Weight
Straight	18 x 10 x 6" H	0.75 sq. ft.	64 lbs.	8	3	24 (18 sq. ft.)	1,586 lbs.
Half Unit	6 x 10 x 6" H	0.38 sq. ft.	32 lbs.			12 (4.56 sq. ft.)	434 lbs.

To estimate number of units, divide total sq. ft. by 0.75.

# Sapphire 6 and Sapphire XL Walls

Rockwood Retaining Walls

## Sapphire 6 Features

- Straight face, smooth top, curved bottom
- Partial cores equal less weight
- Efficient to build, rear-lip system, 1.0" set back
- Self-capping or cap with 3" or 4" Universal Cap
- Available by layer or pallet
- Colors: Beechwood, Cascade, Santa Fe, Gray

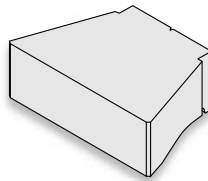

*Sapphire 6's radius bottom eliminates the need for cleaning courses, saving time and hassle. Its rear-lip automatically creates a 1" setback.*

## Sapphire XL Features

- Straight face, open cores
- Efficient to build, rear-lip system, 1.0" set back
- Cap with 3" or 4" Universal Cap
- Available by pallet
- Colors: Gray, Sandstone

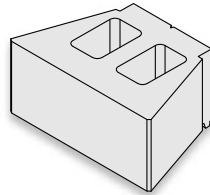

Block	Size	Face Area	Weight	Units/Layer	Layers	Units/Pallet	Pallet Weight
Sapphire 6	17.25 x 12 x 6" H	0.75 sq. ft.	68 lbs.	9	5	45 (33.75 sq. ft.)	3,100 lbs.
6" Corner	16 x 8 x 6" H	0.66 sq. ft.	61 lbs.	12	4	48 (32 sq. ft.)	3,002 lbs.
Sapphire XL	18 x 12 x 8" H	1.0 sq. ft.	81 lbs.	9	4	36 (36 sq. ft.)	2,956 lbs.
8" Corner**	18 x 9 x 8" H	1.0 sq. ft.	100 lbs.	5	4	20 (20 sq. ft.)	2,050 lbs.

Corners are split on one long and one short side. \*\* Rochester and Beaver Dam only.

# Cottage Stone Wall

Rockwood Retaining Walls

## Features

- Beveled face, ideal for small garden walls, tree rings and planters
- Curved bottom aids fast install
- 0.5" setback
- Cap with Mini Cap
- Cannot be double stacked
- Available by pallet
- Colors: Brown, Gray, Sandstone, Sandstone Brown

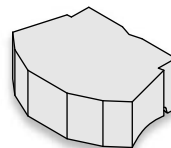

Size	Face Area	Weight	Units/Layer	Layers	Units/Pallet	Pallet Weight
12 x 8.5 x 4" H	0.33 sq. ft.	25 lbs.	16	6	96 (31.68 sq. ft.)	2,450 lbs.

To estimate number of units, divide total sq. ft. by 0.33

# Legend Wall (special order)

Rockwood Retaining Walls

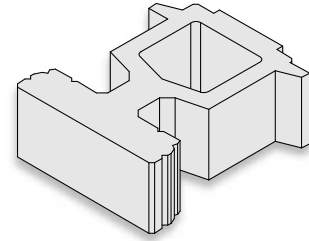

## Features

- The ultimate block for challenging applications
- Straight or beveled face options
- Efficient to build, one-unit system
- 1.0" setback, adjustable
- Special order, can be made in any color

Face	Size	Face Area	Weight	Units/Layer	Layers	Units/Pallet	Pallet Weight
Straight	18 x 22 x 8" H	1.0 sq. ft.	131 lbs.	4	4	16 (16 sq. ft.)	2,146 lbs.
Beveled	18 x 22 x 8" H	1.0 sq. ft.	125 lbs.	4	4	16 (16 sq. ft.)	2,050 lbs.

# Stonegate Wall

Keystone Retaining Wall Systems



## Features

- Three-piece\*, one-pallet system
- Vertical or adjustable setback
- Tumbled, aged appearance
- Cap with Lakeland Block or Chiseled Cap

Available by pallet.

## Colors

- Beechwood
- Bluestone
- Santa Fe

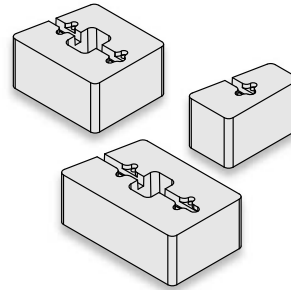

Name	Size	Back	Face Area	Weight	Sets/Layer	Layers	Sets/Pallet	Pallet Weight
Unit 16/14	16 x 10 x 6" H	14" W						
Unit 12/10	12 x 10 x 6" H	10" W	1.41 sq. ft.	140 lbs.	8	3	24 (33.84 sq. ft.)	3,250 lbs
Unit 6/4	6 x 10 x 6" H	4" W						

\* Dry stack/pin connection method (1-2 SHOULDERED pins required per unit; .5 x 3.75" L, 100/Box, 24,200/Pallet).

# Compac Wall

Keystone Retaining Wall Systems

## Features

- Straight-split face only
- 1.0" set back
- Cap with 4" Universal or Chiseled Cap

Available by pallet.

## Colors:

- Sandstone
- Gray

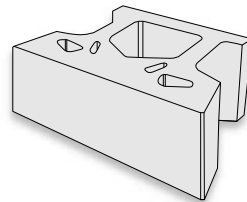

Name	Size	Face Area	Weight	Units/Layer	Layers	Units/Pallet	Pallet Weight
Block	18 x 12 x 8" H	1 sq. ft.	78 lbs.	9	4	36 (36 sq. ft.)	2,860 lbs.
Corner	18 x 9 x 8" H	1 sq. ft.	100 lbs.	10	2	20 (20 sq. ft.)	2,050 lbs.

\* Dry stack/pin connection method (1-2 NON-SHOULDERED pins required per unit; .5 x 5.25" L, 100/Box, 24,000/Pallet).

# Standard Wall (special order)

Keystone Retaining Wall Systems

## Features

- Adjustable setback
- Strong, structural retaining wall system
- Dry stack/pin connection method (1-2 pins required per unit)
- Cap with Rockwood Universal cap

## Colors

- Sandstone
- Gray

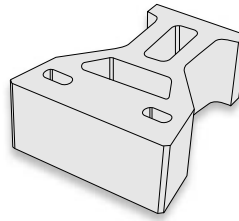

Can be made in any color. Minimum quantity required, customer must take entire production run. Returns not allowed.

\* Dry stack/pin connection method (1-2 NON-SHOULDERED pins required per unit; .5 x 5.25" L, 100/Box, 24,000/Pallet).

Size	Face Area	Weight	Units/Layer	Layers	Units/Pallet	Pallet Weight
18 x 21 x 8" H	1 sq. ft.	105 lbs.	9	2	18 (18 sq. ft.)	1,940 lbs.

# Versa-Lok Standard Wall

Versa-Lok Retaining Wall Systems

## Features

- Split-face STANDARD blocks build straight or curved retaining walls
- Split block for corner and freestanding wall construction
- Setback: 0.75"/unit (7°) or vertical
- Cap with matching 3" universal wall caps
- Limited delivery areas in WI, IL and Indiana

## Colors

- Buff
- Moonlight Gray
- Carmel



Versa-Tuff pins

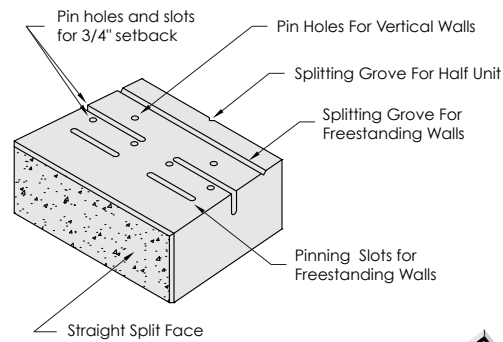

Size	Face Area	Weight	Units/Layer	Layers	Pallet Weight
14/16 W x 12 D x 6" H	0.667 sq. ft.	82 lbs.	40	4	3,350 lbs.
Versa-Tuff pins			100/Bag		

Refer to actual product samples when making color selection.

## ONLINE HARDSCAPES CALCULATOR

Quickly and easily calculate paver and materials requirements from your desktop or mobile device. Send yourself a PDF of the results for your project planning.

Go to: [www.rochesterpc.com/estimator/](http://www.rochesterpc.com/estimator/)



# Recon Wall

Recon Wall Systems

## Features

- Strong, wet cast blocks 1,457 to 4,088 lbs.
- 24" to 84" D x 48" W x 16" H
- Regular corner and cap blocks
- Half block (24" or 39" deep)
- Full fence or full high end/cap blocks
- Passed current WI DOT requirements

## Color/Fascia

- Available in two unique faces
- Gray (stained after construction)

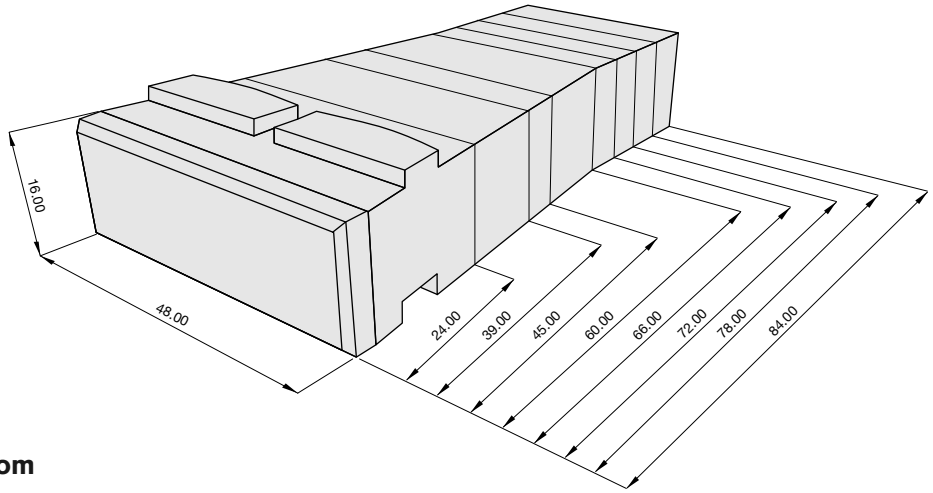

Installation details at: [www.reconwalls.com](http://www.reconwalls.com)

Block	Size W x D x H	Face Area	Weight
Full Base Block - 24"	48 x 24 x 16" H	5.33 sq. ft.	1,457 lbs.
Full Base Block - 39"	48 x 39 x 16" H	5.33 sq. ft.	2,201 lbs.
Full Base Block - 45"	48 x 45 x 16" H	5.33 sq. ft.	2,491 lbs.
Full Base Block - 60"	48 x 60 x 16" H	5.33 sq. ft.	3,115 lbs.
Full Base Block - 66"	48 x 66 x 16" H	5.33 sq. ft.	3,416 lbs.
Full Base Block - 72"	48 x 72 x 16" H	5.33 sq. ft.	3,660 lbs.
Full Base Block - 78"	48 x 78 x 16" H	5.33 sq. ft.	3,902 lbs.
Full Base Block - 84"	48 x 84 x 16" H	5.33 sq. ft.	4,088 lbs.
Full Top Block - 24"	48 x 24 x 16" H	5.33 sq. ft.	971 lbs.
Regular Corner	48 x 24 x 16" H	5.33 sq. ft.	1,401 lbs.
Corner Top	48 x 24 x 16" H	5.33 sq. ft.	1,103 lbs.
Half Block 24"	48 x 24 x 16" H	5.33 sq. ft.	667 lbs.
Half Block 39"	48 x 36 x 16" H	5.33 sq. ft.	973 lbs.
Capstone	48 x 26 x 6.5" H	2.16 sq. ft.	551 lbs.
Fence Middle Block	16 x 48 x 24" H	2.66 sq. ft.	1,449 lbs.
Fence Middle End Block	16 x 48 x 24" H	2.66 sq. ft.	1,476 lbs.
Half Fence Middle End Block	16 x 24 x 24" H	2.66 sq. ft.	709 lbs.
Guardrail Middle Block	16 x 48 x 24" H	2.66 sq. ft.	1,373 lbs.





# Outcropping Wall

Rosetta Hardscapes

## Features

- Strong, wet cast wall blocks for serious performance and curb appeal
- 6", 12", 18" and 24" heights
- Fourteen unique shapes in 2' to 6' widths
- 15° setback (3")
- Lifting device required, available for purchase or rent (53 lbs.)
- Available by pallet

## Colors

- Copper Canyon
- Fond du Lac
- Pacific Gray



Pallet	Sizes	Pallet	Pallet Weight
Pallet A	3.5' x 1", 4' x 1', 5' x 1', 5.5' x 1'	18 sq. ft.	4,000 lbs.
Pallet B	2' x .5', 3' x .5', 3' x 1', 4' x .5', 4.5' x 1', 6' x 1'	18 sq. ft.	4,000 lbs.
Pallet C	2' x .5', 3' x .5', 5' x 1.5', 4' x 2'	18 sq. ft.	4,000 lbs.
Corner	30" x 48" x 12" H (3 per pallet)	19.5 sq. ft.	3,650 lbs.

## Outcropping Patterns

Each pattern is 90 sq. ft. = (2) A pallets + (2) B pallets + (1) C pallet

2' x 45' Pattern

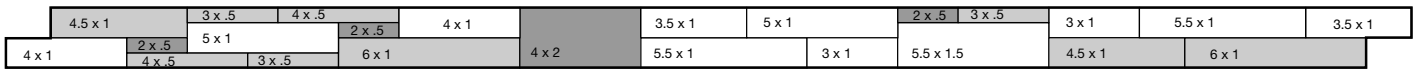

3' x 30' Pattern

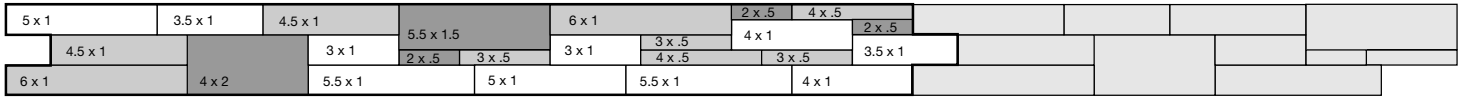

4' x 22.5' Pattern

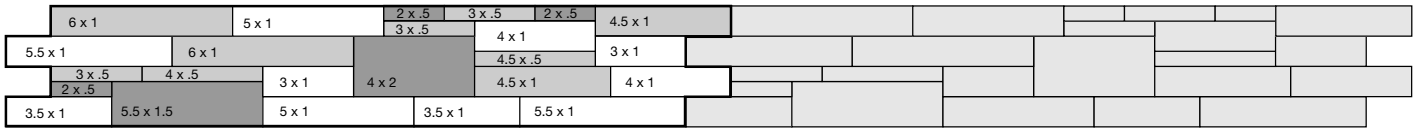

5' x 18' Pattern

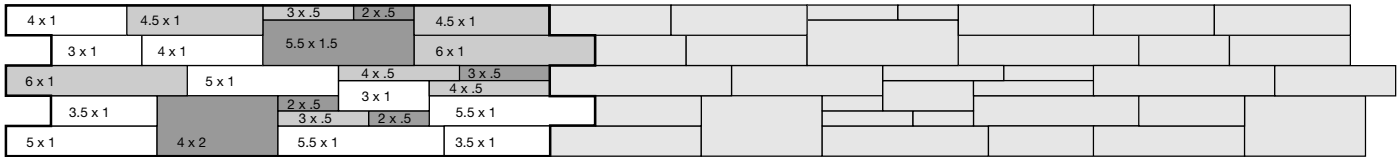

# Irregular and Dimensional Steps

Rosetta Hardscapes

- Wet cast, varied appearance
- 3.5 to 6 ft. wide x 7" H
- Available by pallet

## Colors

- Copper canyon
- Fond du Lac
- Pacific Gray



Size	Weight	Units/Pallet	Pallet Weight
Irregular x 7" H	493 lbs.	6	3,008 lbs.
72 x 30 x 7" H (special order)	1,320 lbs.	3	4,010 lbs.

# Kodah Wall

Rosetta Hardscapes

## Features

- Four-unit system, two-sided, wet cast blocks
- Builds freestanding near-vertical seat and retaining walls
- Matching corner/end blocks
- 3/4" setback
- Available by pallet

## Colors

- Copper Canyon
- Fond du Lac
- Pacific Gray



Pallet	Size	Face Area	Weight	Units/Pallet	Pallet Weight
Wall Pallet	42 x 10.5 x 6" H	1.75 sq. ft.	200 lbs.	6	Sold in sets (21 sq. ft.) 2,400 lbs
	30 x 10.5 x 6" H	1.25 sq. ft.	140 lbs.	3	
	21 x 10.5 x 6" H	0.88 sq. ft.	100 lbs.	6	
	12 x 10.5 x 6" H	0.50 sq. ft.	50 lbs.	3	
Corner Pallet	21 x 10.5 x 6" H	0.88 sq. ft.	100 lbs.	24 (21 sq. ft.)	2,400 lbs.

# Belvedere Wall

Rosetta Hardscapes

## Features

- 64 unique stone textures create the look of naturally weathered stone
- Two-sided units create vertical pillars, freestanding walls and outdoor features
- Strong and versatile retaining wall system
- 1/2" setback
- Available by pallet

## Colors

- Copper Canyon
- Fond du Lac
- Pacific Gray



## RETAINING WALL PALLET

Size	Back	Face Area	Weight	Units/Pallet	Pallet Weight
6 x 9 x 3" H	4" W	0.125 sq. ft.	10 lbs.	12	Sold in sets
12 x 9 x 3" H	10" W	0.25 sq. ft.	22 lbs.	12	2,475 lbs. (27 sq. ft.)
18 x 9 x 3" H	16" W	0.375 sq. ft.	36 lbs.	12	
6 x 9 x 6" H	4" W	0.25 sq. ft.	21 lbs.	12	
12 x 9 x 6" H	10" W	0.50 sq. ft.	42 lbs.	12	
18 x 9 x 6" H	16" W	0.75 sq. ft.	67 lbs.	12	

**CORNER PALLET** One pallet of corner block builds a 24 x 24 x 36" pillar

Size	Back	Face Area	Weight	Units/Pallet	Pallet Weight
15 x 9 x 3" H	14" W	0.313 sq. ft.	30 lbs.	16	Sold in sets
15 x 9 x 6" H	14" W	0.625 sq. ft.	58 lbs.	16	1,520 lbs. (24 sq. ft.)

**COPING (CAPS) PALLET** Caps can only be purchased in 11 lineal feet increments.

Size	Back	Face Area	Weight	Units/Pallet	Pallet Weight
4 x 10.25 x 2.25" H	6" W	0.33 ln. ft.	9 lbs.	24	Sold in sets
12 x 10.25 x 2.25" H	10" W	1.0 ln. ft.	20 lbs.	24	1,552 lbs. (33 ln. ft.)
18 x 10.25 x 2.25" H	16" W	1.5 ln. ft.	30 lbs.	12	
18 x 10.25 x 2.25" H Right End	17" W	1.5 ln. ft.	29 lbs.	6	
18 x 10.25 x 2.25" H Left End	17" W	1.5 ln. ft.	34 lbs.	6	
27 x 27 x 2.5" H Pillar Cap		5.06 sq. ft.	150 lbs.	10	1,550 lbs. (50.6 sq. ft.)

Rosetta Tech Guides available online. [www.rosettahardscapes.com](http://www.rosettahardscapes.com)

# Retaining Wall Caps

Rockwood Retaining Walls

• Available by pallet or layer

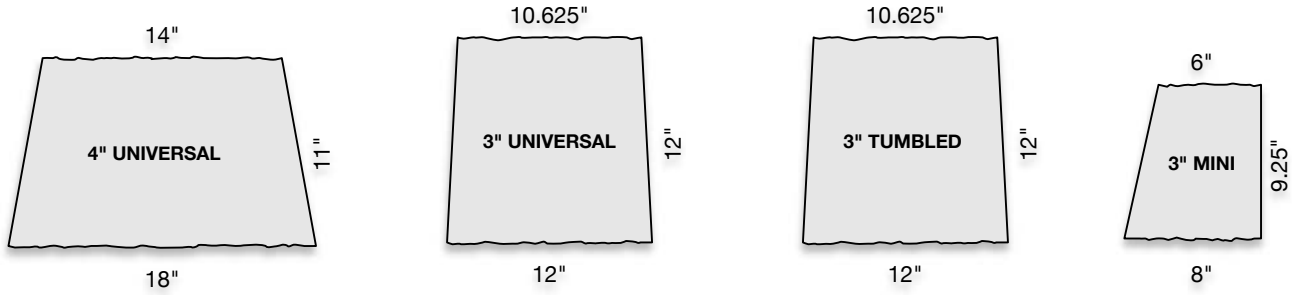

### 4" Universal Cap Colors

- Bluestone
- Brown
- Charcoal
- Gray
- Sandstone
- Sandstone Brown
- Santa Fe

### 3" Universal Cap Colors

- Beechwood
- Bluestone
- Gray
- Santa Fe

### 3" Tumbled Cap Colors

- Beechwood
- Bluestone
- Cascade (NEW)
- Santa Fe

### Mini Cap Colors

- Brown
- Charcoal
- Gray
- Sandstone
- Sandstone Brown



Cap	Size	Face	Weight	Units/Layer	Layers	Units/Pallet	Pallet Weight
4" Universal	18 W x 11 x 4" H (Front)	1.5 ln. ft.	54 lbs.	9	5	45 (67.5 ln. ft.)	2,480 lbs
	14 W x 11 x 4" H (Back)						
<i>To estimate Universal Cap, divide wall length by 1.33</i>							
3" Universal and Tumbled	12 x 12 x 3" H (Front)	1 ln. ft.	26 lbs.	12	4	48 (72 ln. ft.)	1,298 lbs.
	10.625 x 12 x 3" H (Back)						
Mini Cap	8 x 9.25 x 3" H (Front)	0.67 ln. ft.	15.2 lbs.	52	2	104 (69 ln. ft.)	1,630 lbs.
	6 x 9.25 x 3" H (Back)						
<i>To estimate Mini Cap, divide wall length by 0.58</i>							

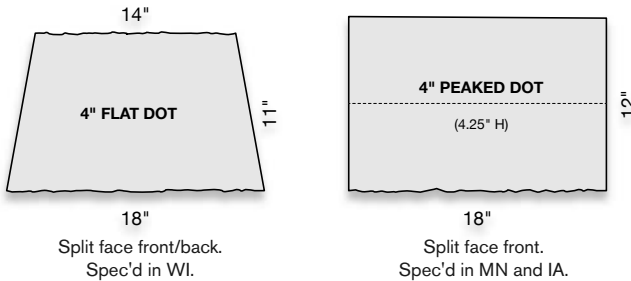

• Sandstone or Gray color

DOT Cap	Size	Face	Weight	Units/Layer	Layers	Units/Pallet	Pallet Weight
4" Flat Cap	18 W x 11 x 4" H (Front)	1.33 ln. ft.	55 lbs.	9	5	45 (60 ln. ft.)	2,520 lbs.
	14 W x 11 x 4" H (Back)						
4" Peaked Cap	18 W x 12 x 4" H	1.5 ln. ft.	70 lbs.	8	4	32 (48 ln. ft.)	2,290 lbs.

# Wet Cast Steps

Silver Creek Stoneworks

## Barn Plank Step Colors

- Mahogany
- Weathered Gray

## Chiseled Step Colors

- Bluestone
- Buff
- Indiana Limestone

Available by piece.

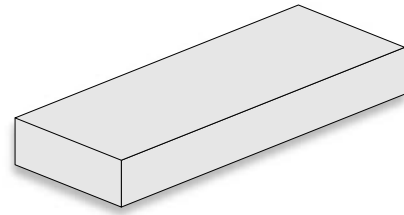

Name	Size	Weight	Units/Pallet	Pallet Weight	Details
Barn Plank Step	48 x 18 x 5.75" H	450 lbs.	4	1,850 lbs.	Detailed grain on 5-sides
Chiseled Step	48 x 18 x 5.75" H	450 lbs.	4	1,850 lbs.	One sided/smooth top or three sides/rough top

Notes: Available by pallet only. One and three sided steps CANNOT be used together.

# Grand Step

Interlock Concrete Products

- Smooth riser w/front bevel on one side, straight split on the other.

Available by piece.

## Colors

- Beechwood
- Buff
- Charcoal
- Natural

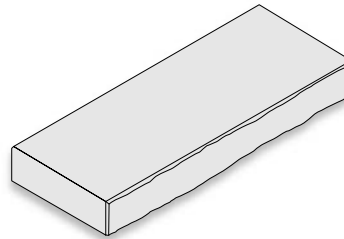

Split/beveled face riser one side...

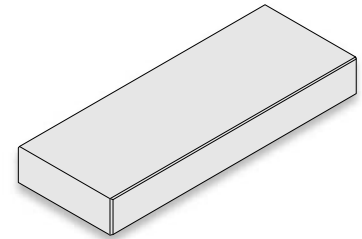

...smooth/beveled face riser on the other.

Size	Area	Weight	Units/Pallet	Pallet Weight
48 x 18 x 6" H	6.0 sq. ft.	409 lbs.	6 (32 sq. ft.)	2,504 lbs.

# Stepping Stones

Silver Creek Stoneworks

- Strong, wet cast reproductions of handcrafted limestone originals
- 1.75" H, average 3.75 sq. ft. ea.
- Four unique shapes, chiseled edge

Full pallets only, CANNOT be double stacked.

## Colors

- Bluestone
- Indiana Limestone
- Buff

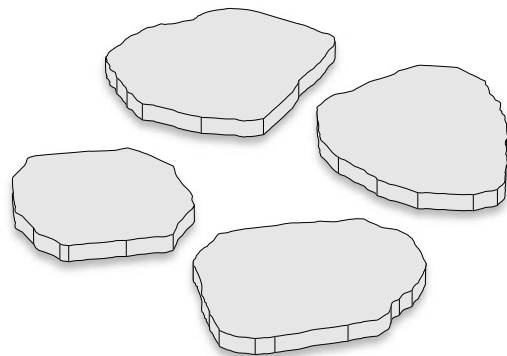

Sets	Weight	Sets/Pallet	Pallet Weight
5 each of 4 sets (20)	208 lbs.	5 (75 sq. ft.)	1,090 lbs.

# Chiseled Caps and Tops

Silver Creek Stoneworks

• Available by pallet or piece

## Colors

- Bluestone
- Indiana Limestone
- Buff

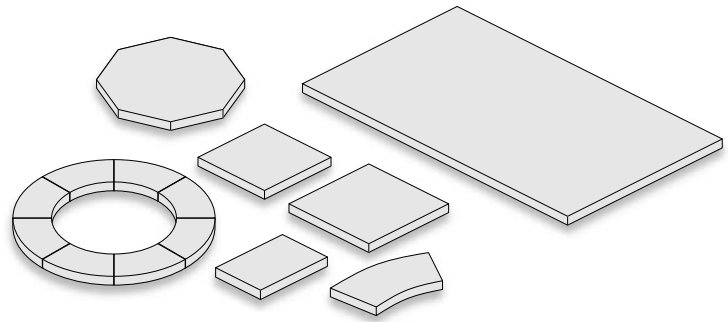

Name	Size	Face Area	Weight	Units/Pallet	Pallet Weight
25" Pillar Cap	25 x 25 x 2.25" H	4.34 sq. ft.	110 lbs.	6 (26.04 sq. ft.)	710 lbs.
30" Pillar Cap	30 x 30 x 2.25" H	6.25 sq. ft.	125 lbs.	6 (37.50 sq. ft.)	800 lbs.
12" Radius Seatwall Cap	18.75 x 12 x 2.25" H	1.56 sq. ft.	39 lbs.	15 (23.40 sq. ft.)	635 lbs.
12" Straight Seatwall Cap, 2-sided	24 x 12 x 2.25" H	2 sq. ft.	53 lbs.	15 (30 sq. ft.)	845 lbs.
12" Straight Seawall Cap, 3-sided	24 x 12 x 2.25" H	2 sq. ft.	53 lbs.	15 (30 sq. ft.)	845 lbs.
2-sided Bar Top*	36 x 48 x 2.25" H	12 sq. ft.	327 lbs.	1 (12 sq. ft.)	377 lbs.
3-sided Bar Top*	36 x 48 x 2.25" H	12 sq. ft.	327 lbs.	1 (12 sq. ft.)	377 lbs.
Octagon Top*	36 x 36 x 2.25" H	-	238 lbs.	1	238 lbs.
Fire Ring Cap	10 W x 2.25" H	-	298 lbs.	8	298 lbs.

\*Indiana Limestone color only. Tops and caps CANNOT be double stacked.

# Super-Stik Adhesive

Product	Item#	Details
10.5 oz. tube	1140001	12/case, 108 cases/pallet
29 oz. tube	1140002	12/case, 44 cases/pallet

# Geo-Grid

Strata Systems

Product	Item#	Roll Size	Weight	Coverage
Strata Dealer Rolls	1178100	4 x 50'		22.22 sq. yd.
Strata 200	1178010	6 x 300'	95 lbs.	200 sq. yd.
Strata 350	1178300	6 x 300'	100 lbs.	200 sq. yd.

# Sleeve-It

Strata Systems (pre-engineered fence post anchoring solution)

Product	Item#	Minimum	Pallet
Sleeve-It	SD1	5 units (1 pkg.)	45 units

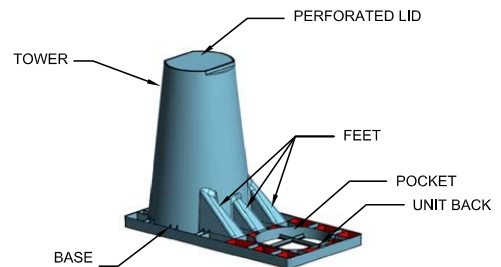

# Snap-Edge Paver Restraint

SEK Surebond

Product	Item #	Details	Pallets
Paver Edge Restraint 8' piece	ESEPR96-672	24/bundle	28 bundles
Low Profile 6' 8"	ESELP80-672	24/bundle	28 bundles
10" Spikes	SSBR10-150-048	150/box	48 boxes

# Bullnose Paver

Interlock Concrete Products

• Smooth surface, full radius front  
Available by pallet or layer.



**Colors**

- Buff
- Brown
- Natural
- Onyx

Size	Face Area	Weight	Units/Layer	Layers	Units/Pallet	Pallet	Pallet Weight
12 x 6 x 2.375" H	0.50 sq. ft.	13.06 lbs.	48	3	144	72 sq. ft.	1,930 lbs.

# Bullet Edger

Interlock Concrete Products

Available by pallet.

**Colors**

- Beechwood
- Buff
- Carmel
- Charcoal
- Natural (new)



Size	Unit In. ft.	Weight	Units/Layer	Layers	Units/Pallet	Pallet In. ft.	Pallet Weight
4 x 12.25 x 4" H	0.9375 In. ft.	14 lbs.	36	5	180	168.75 In. ft.	2,570 lbs.

To estimate number of units, divide In. ft. by 0.9375.

# Classic Edger

Rockwood Retaining Walls

• Patented T-lock design helps prevent frost heave  
Available by pallet.



**Colors**

- Brown
- Charcoal
- Gray
- Red/Black
- Sandstone

Size	Unit In. ft.	Weight	Units/Layer	Layers	Units/Pallet	Pallet In. ft.	Pallet Weight
4 x 10 x 2.75" H	0.83 In. ft.	9 lbs.	48	5	240	200 In. ft.	2,223 lbs.

Estimate the Classic Edger, divide lineal ft. by 0.83.

# Tumbled Granite Edger

Rockwood Retaining Walls

• Smooth sides, split face, tumbled  
Available by pallet.



**Colors**

- Bluestone
- Santa Fe

Size	Weight	Units/Layer	Layers	Units/Pallet	Pallet	Pallet Weight
12 x 4 x 4" H	16 lbs.	32	5	160	160 In. ft.	2,610 lbs.

# Alliance Gator Sands, Sealers, Cleaners, Adhesive and Accessories

Item (call for pallet weights)	Item Number	Package	Min. Qty.	Pallets
G2 Supersand Beige	G2SUPERSAND001B	50 lb. bag	1	56 bags
G2 Supersand Gray	G2SUPERSAND002G	50 lb. bag	1	56 bags

## Gator Dust Bond (Large joint application)

Beige	GATOR001	50 lb. bag	1	56 bags
Gray	GATOR002	50 lb. Bag	1	56 bags

## G2 Gator Maxx Bond (Alliance)

Beige	G2GATORMAXX01	50 lb. bag	1	56 bags
Gray	G2GATORMAXX02	50 lb. bag	1	56 bags
Ivory	G2GATORMAXX03	50 lb. bag	1	56 bags
Black Diamond	G2GATORMAXX04	50 lb. bag	1	56 bags

## Base

Gator Base	GATORBASE01	10/pkg	1 pkg	12 packages
Gator Base Screws	GATORSCREW001	50/pkg	1 pkg	40 cases (20 pkg's ea.)

## Binders

Rock Bond (Binder Only)	GATORROCK02	1 gal.	Box (4)	24 boxes /96 gals.
Rock Bond Kit (Binder & Rock)	GATORROCK05	1 pail	1 pail	48 pails/240 gals.
Stone Bond XP pail	SUPERB-07	5 gal.	1 pail	48 pails/240 gals.
Stone Bond XP	SUPERB-09	1 gal.	Box (4)	24 boxes /96 gals.

## Cleaners

Efflorescence Cleaner	GATORCLEAN03	1 gal.	Box (4)	24 boxes /96
Efflorescence Cleaner	GATORCLEAN04	5 gal. pail	1 pail	48 pails
Cleaner Shampoo	GATORCLEAN07	1 gal.	Box (4)	24 boxes /96
Cleaner Shampoo	GATORCLEAN08	5 gal. pail	1 pail	48 pails
Rubber, Paint & Tar Remover	GATORCLEAN01	1 qt.	Box (6)	24 boxes /144
XP Oil & Grease Remover	GATORCLEAN0212	1 qt.	Box (6)	24 boxes /144
Rust Remover	GATORCLEAN51	1 qt.	Box (6)	24 boxes /144
Gatorene	GATORCLEAN10	1 gal.	Box (4)	24 boxes /96

## Solvent Based Sealers

Seal Satin Look	GATORSEAL06	1 gal.	Box (4)	24 boxes /96
Seal Satin Look	GATORSEAL05	5 gal. pail	1 pail	48 pails
Seal Wet Look	GATORSEAL02	1 gal.	Box (4)	24 boxes /96
Seal Wet Look	GATORSEAL01	5 gal. pail	1 pail	48 pails
Seal Re Sealer	GATORRESEALER02	1 gal.	Box (4)	24 boxes /96
Seal Re Sealer	GATORRESEALER01	5 gal. pail	1 pail	48 pails
Seal Wet Cast Sealer Low Gloss + Enhancer	GATORSEAL70	1 gal.	Box (4)	24 boxes /96
Seal Wet Cast Sealer Low Gloss + Enhancer	GATORSEAL71	5 gal. pail	1 pail	48 pails

## Water Based Sealers

Seal Natural Look	GATORSEAL04	1 gal.	Box (4)	24 boxes /96 gals.
Hybrid Enhancer + Low Gloss	GATORHYBRID40	1 gal.	Box (4)	24 boxes /96 gals.
Hybrid Enhancer + Low Gloss	GATORHYBRID41	5 gal. pail	1 pail	48 pails/240 gals.
Seal Natural Stone Enhancer Zero Gloss	GATORSEAL50	1 gal.	Box (4)	24 boxes /96 gals.
Seal Wet Cast Sealer Zero Gloss	GATORSEAL60	1 gal.	Box (4)	24 boxes /96 gals.
Seal Wet Cast Sealer Zero Gloss	GATORSEAL61	5 gal. pail		48 pails/240 gals.

## Nails and Permeable Chips

Nails Common 10 (180/box)	NAIL COM 10	50 lbs. box	1 box	48 boxes
Nails Common 12 (130/box)	NAIL COM 12	50 lbs. box	1 box	48 boxes
Nails Spiral 10 (250/box)	NAIL SPIR 10	50 lbs. box	1 box	48 boxes
Nails Spiral 12 (210/box)	NAIL SPIR 12	50 lbs. box	1 box	48 boxes
Aqua Rock for Permeable Pavers (Granite Gray)	GATORAQUA01	50 lbs. bag	1 bag	56 bags

## Adhesives

Block Bond XP Polyurethane Low VOC-Black (12 Tubes)	GBBXP 10.3	10.3 oz.	1 case	90/pallet
Block Bond XP Polyurethane Low VOC-Black (12 Tubes)	GBBXP28	28 oz.	1 case	60/pallet

## EDGING

Gator Edge Rigid	GATOREDGE001	8" length	24 pcs./bundle	672/pallet
Gator Edge Flex	GATORFLEX001	8" length	24 pcs./bundle	672/pallet
Gator Edge Mini-Pro	GATOREDGE003	8" length	24 pcs./bundle	384/pallet



## GATOR BASE

- Acts like a big snowshoe and actually replaces 6" of crushed aggregate base
- Will outperform an aggregate base in freeze/thaw cycles
- Easy to work with...all types of weather, walk on it, slide pavers into place, etc.
- Saves labor, speeds up installation considerably
- Gator Base Screws secure Gator Base's outside perimeter, creating strong lateral support.
- Pedestrian use only

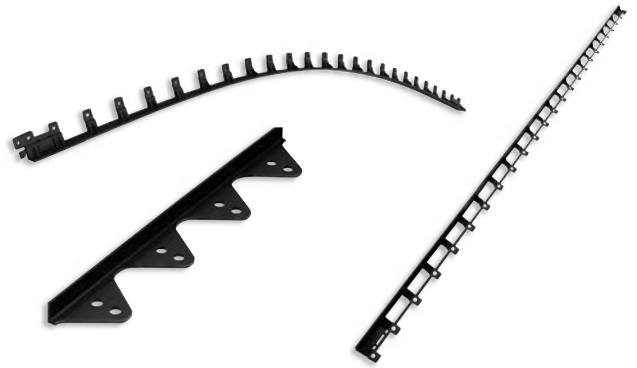

## GATOR EDGE

- Use Gator Edge rigid or flexible (1-1/2" profile) in typical paving applications
- Use Gator Edge Mini (1" profile) with natural stone of all types
- Use Gator Tile Edge (5/8" profile) with porcelain tile
- All 3 profiles can be used with Gator Screws for a secure connection on Gator Base

**NEW PRODUCT**

## NITRO SAND

- Can be applied in wet or dry weather
- Must be applied on wet paving
- Great for use in open-graded base applications
- Permeable upon installation
- Cures solid within 18 hours
- Leftover sand can be stored for future use



**NEW PRODUCT**

## XTREME EDGE

- Great for use in open-graded base applications
- Great for use on flagstone paving applications
- Poly-modified concrete provides flexibility
- Smaller fractured aggregates provide workability
- 3-D matrix fibers expand during mixing and provide durability
- A 50 lb. bag mixes easily and quickly with only a half-gallon of water



## GATOR BASE XP ADHESIVE

- High strength polyurethane and low VOC
- Permanent bond in 24 hours
- Apply under damp conditions to create a faster setting and stronger bond
- Use with steps, wall courses and caps, pool coping and paver overlays



## G2 GATOR MAXX

- For use in patio, walkway, pool deck and terrace applications
- For use in driveway and motor court applications
- For use in steep slope, street and commercial applications
- Use with concrete pavers, clay pavers and wet cast pavers
- One watering
- 15-minutes rain safe
- Haze free



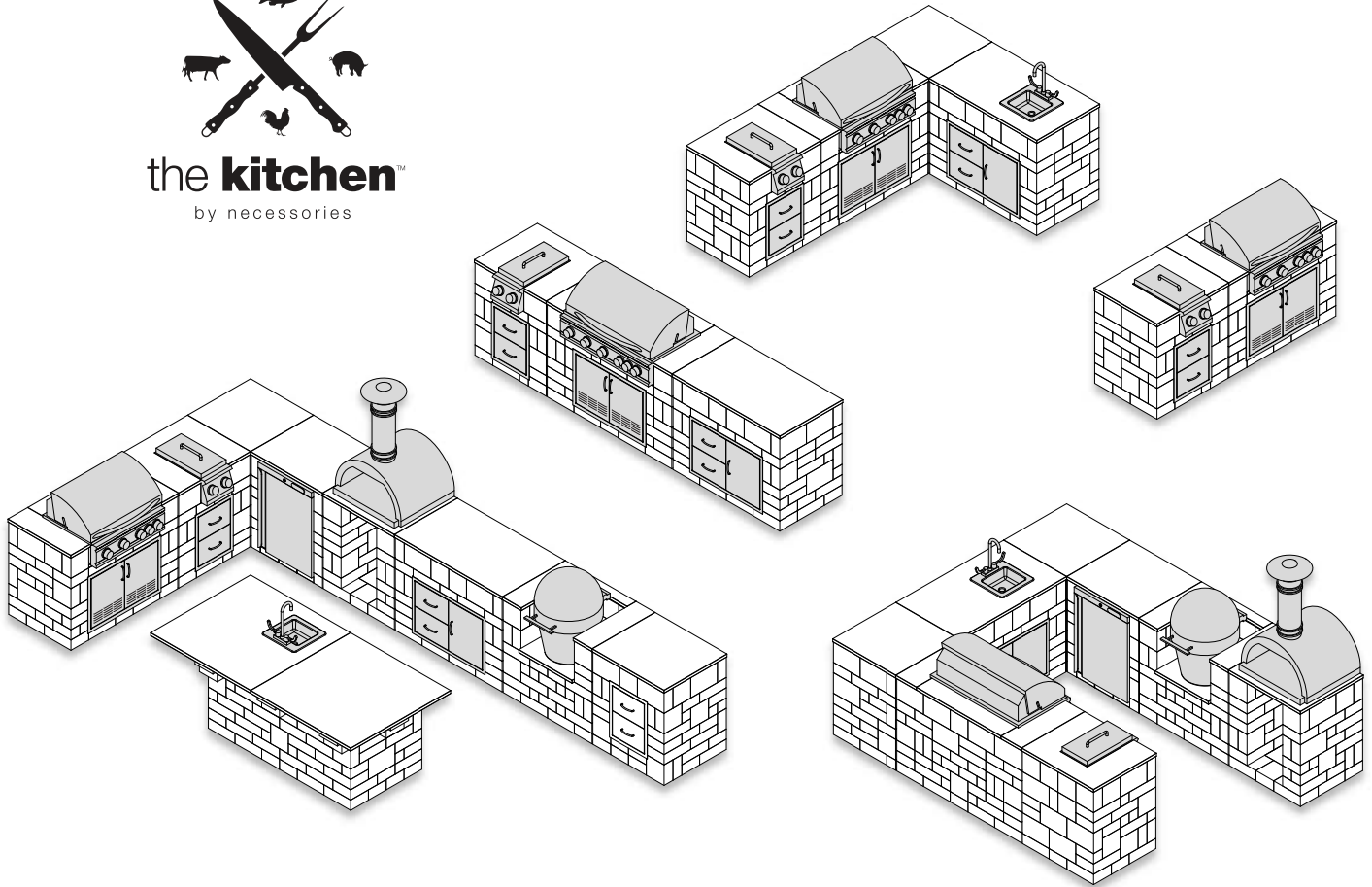

## The kitchen is a collection of granite-topped cabinet kits for backyard baking, grilling, dining and entertaining.

**Elegant, functional and affordable, these quality components and cabinets are ready to assemble in any configuration you can imagine.**

### Affordable luxury

The Kitchen by Necessaries is beautiful, functional and turns backyards into attractive and enjoyable outdoor living spaces. These cabinets come ready to assemble making them easier to install and more affordable than typical masonry structures.

### Easy to build

The Kitchen is a series of individual cabinet kits that come complete with everything needed to build, including precut block and granite tops sized to fit, reinforcements, adhesive, and easy-to-read, step-by-step instructions. Depending on the complexity, most kitchens can be built in a day or less.

### Expand at anytime

Build your Kitchen all at once or add new features over time. Because of their modularity, expanding your outdoor cooking and entertaining space is easy to do at any time.

### Convenient standard features

- Easy-to-read, step-by-step instructions
- Rockwood's multi-piece tumbled Lakeland block
- Premium stainless steel grills and components
- High-grade 3cm granite tops
- Concrete precut and reinforcements sized to fit
- VOC compliant adhesive and gloves

### Earthy colors

The Kitchen features Rockwood Retaining Walls' multi-piece, tumbled Lakeland wall block. Its linear design and aged appearance fit well in landscapes of any style or decor.

**TUMBLED**

# Kitchen Cabinet Kits

Rockwood Retaining Walls

A collection of granite-topped cabinets for backyard baking, grilling, dining and entertaining. Elegant, functional and affordable, these quality components and cabinets are ready to assemble in any configuration you can imagine.



**(NEW) SPRING 2021**

**KITCHEN KITS CAN BE ORDERED WITH OR WITHOUT GRANITE TOPS.**

## Features

- Easy-to-read, step-by-step instructions
- Premium stainless steel grills and components
- Concrete precut and reinforcements sized to fit
- VOC-compliant adhesive and gloves
- High-grade, 3cm Solid Granite Tops in Black Pearle or Viscon White

## Cabinet Colors

- Beechwood
- Bluestone
- Santa Fe

Full specifications available online at: [www.kitchen.outdoorlivingkits.com](http://www.kitchen.outdoorlivingkits.com)

Kit	Size	Pallets	Weight	Build Time
<b>40" Pro Sizzler Grill Cabinet (5 burner)</b>	56 x 28 x 37" H	2	2,890 lbs.	6 hrs.
Summerset Sizzler Pro 40" Grill, 30" vented double doors, grill cover, 12,000 max Btu				
<b>32" Pro Sizzler Grill Cabinet (4 burner)</b>	48 x 28 x 37" H	2	2,535 lbs.	5 hrs.
Summerset Sizzler Pro 32" Grill, 30" vented double doors, grill cover, 12,000 max Btu				
<b>Side Burner Cabinet</b>	32 x 28 x 37" H	2	1,905 lbs.	4 hrs.
#304 stainless steel construction. Push-to-turn knob ignition, easy-glide drawers, 30,000 Btu/hr solid brass burners. 19.5" x 10.5" cooking surface.				
<b>Prep Center Cabinet</b>	48 x 28 x 37" H	2	2,270 lbs.	5 hrs.
Double drawer/door combo.				
<b>Prep Center Cabinet w/Sink</b>	48 x 28 x 37" H	2	2,295 lbs.	6 hrs.
Double drawer/door combo, sink and fixture.				
<b>Refrigerator Cabinet</b>	32 x 28 x 37" H	1	1,035 lbs.	4 hrs.
<b>Two Drawer Cabinet</b>	32 x 28 x 37" H	2	1,985 lbs.	5 hrs.
Easy-glide stainless steel drawers. Fully enclosed stainless steel outside.				
<b>Trash Cabinet</b>	28 x 28 x 37" H	2	1,110 lbs.	3 hrs.
Easy-glide pullout drawer. Accommodates a 12-gallon trash can.				
<b>Smoker Cabinet</b> (smoker not available or included)	40 x 28 x 37" H	1	2,120 lbs.	4 hrs.
<b>Woodbox/Stand Cabinet</b>	32 x 28 x 37" H	1	1,830 lbs.	4 hrs.
<b>Corner Cabinet</b>	28 x 28 x 37" H	1	1,935 lbs.	4 hrs.
<b>Island Cabinet</b>	90 x 45.5 x 37" H	4	4,320 lbs.	8 hrs.
Double drawer/door combo. Base size 65 W x 32.50" D.				
<b>Island Cabinet w/Sink</b>	90 x 45.5 x 37" H	4	4,335 lbs.	9 hrs.
Double drawer/door combo, sink and fixture.				
<b>Deluxe Rotisserie Kit</b> (optional) #304 stainless steel, heavy-duty motor, 25 lb. capacity.				
<b>Grill Cover</b> (replacement)				

Build time assumes two people with limited skills and base work is complete prior to construction.

**Kits are not designed for commercial installations and applications. Kits cannot be returned.**

## Kitchen Grill Kits feature Summerset Pro Sizzler Grills with features that every backyard chef will love.

### Summerset Pro Sizzler Grills:

- #443 and 304 stainless steel construction
- Push-to-turn knob ignition 3" Heat Indicator
- 14,000 BTU #304 cast stainless steel burners
- 15,000 BTU infrared back burner
- Natural gas or propane fuel
- Double-lined hood assures optimal airflow
- 8mm cooking grates won't warp or rust
- Easy-clean briquette system for even heat
- 30" double stainless doors

- LED exterior lights
- Heat zone separators
- Twin Interior cooking lights

### Deluxe Rotisserie: (optional)

- #304 stainless steel, heavy-duty motor and 25 lb. capacity

Pro Sizzler features and rotisserie require 120 volt electrical



 **SUMMERSET**



**the kitchen™**  
by necessities

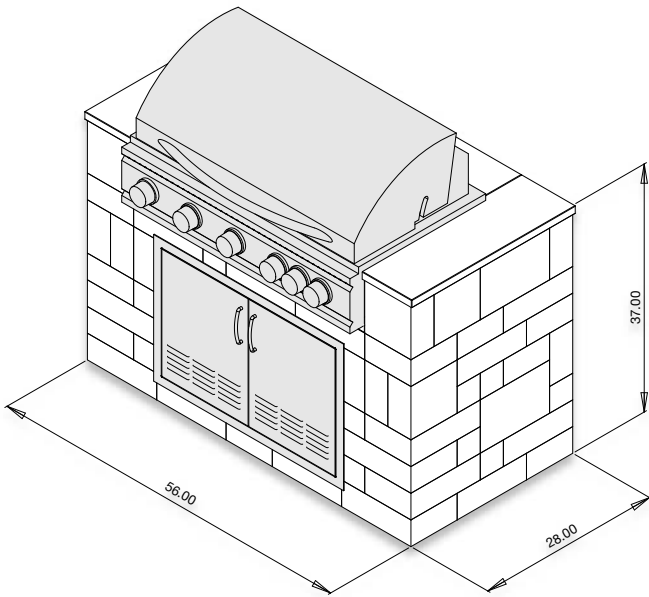

40" Sizzler Pro Grill Cabinet

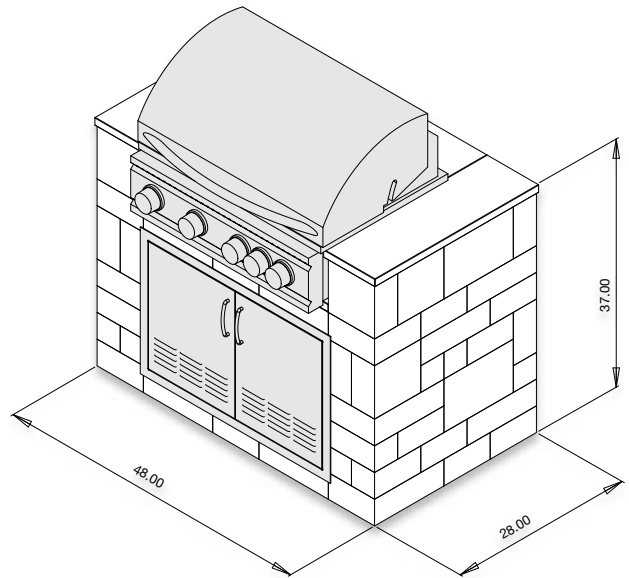

32" Sizzler Pro Grill Cabinet

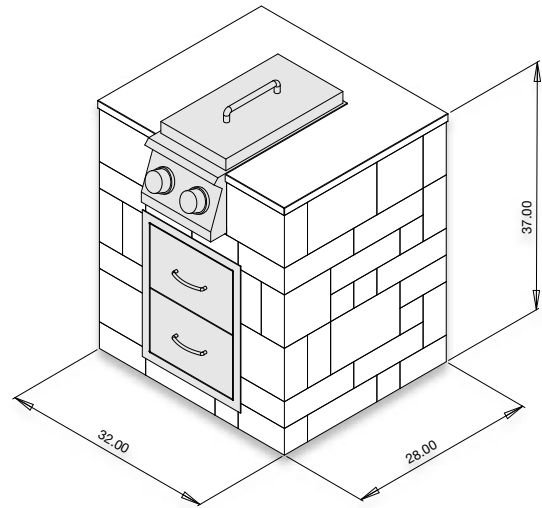

Side Burner Cabinet

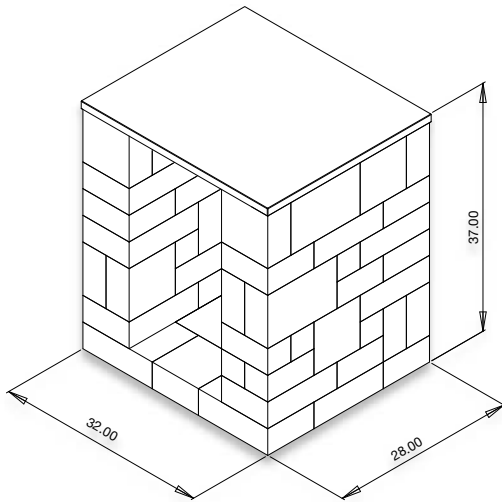

Woodbox/Stand Cabinet

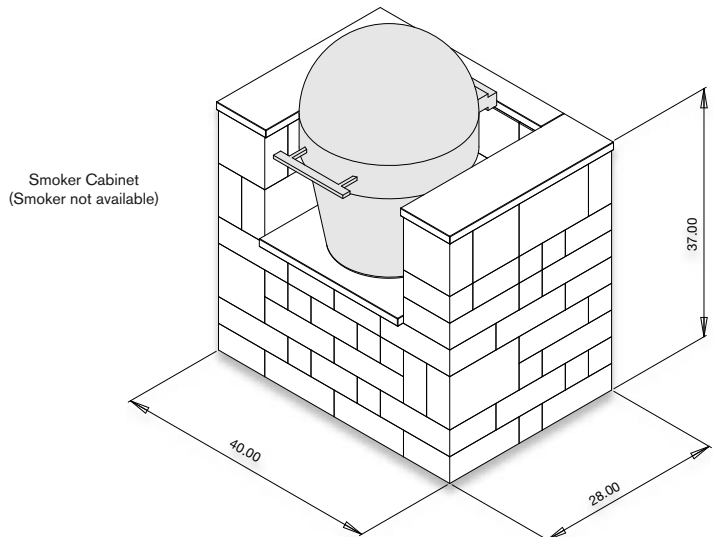

Smoker Cabinet  
(Smoker not available)



Kits are not suitable for commercial installations.  
All dimensions shown in inches.  
Features and specifications subject to change.

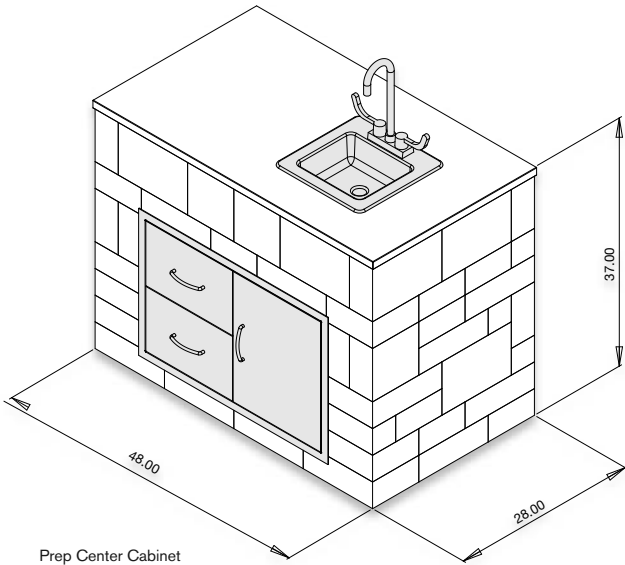

Prep Center Cabinet  
(Optional sink)

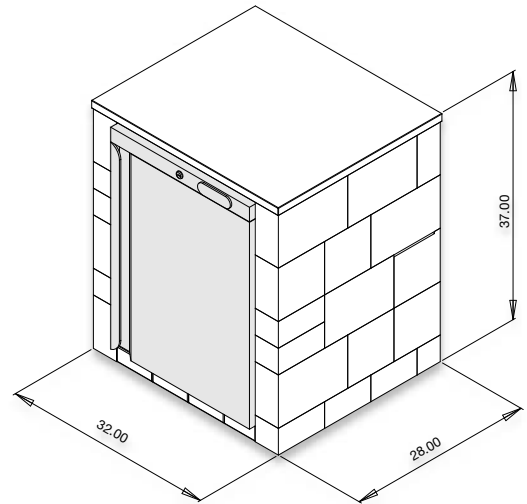

Refrigerator Cabinet  
(Refrigerator not available)

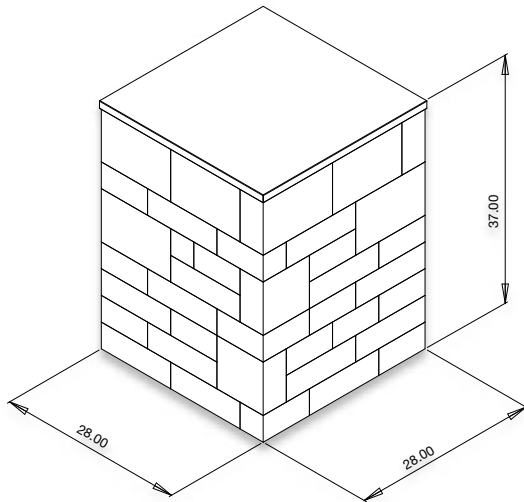

Corner Cabinet

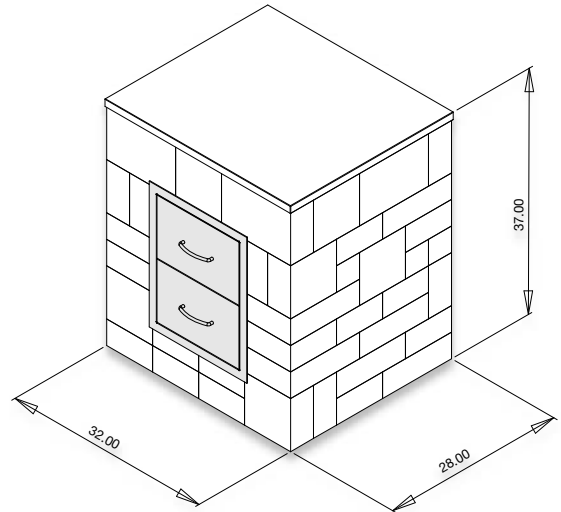

Two Drawer Cabinet

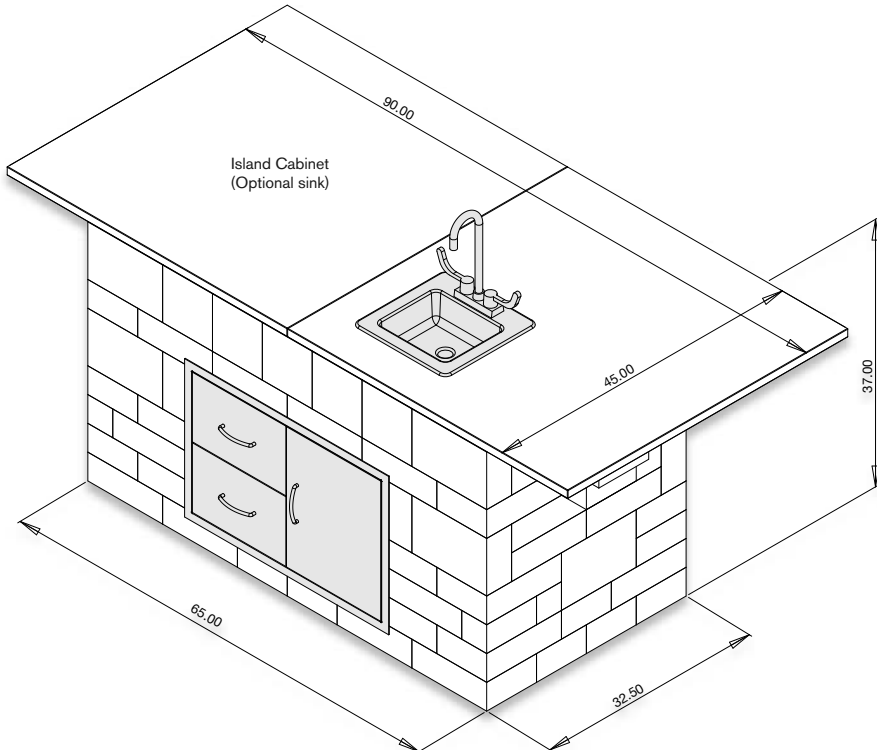

Island Cabinet  
(Optional sink)

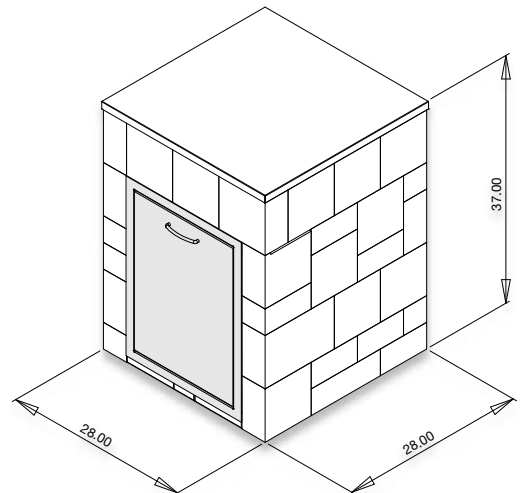

Trash Drawer Cabinet

# Necessaries Outdoor Living Kits

Necessaries is a collection of affordable, ready-to-assemble outdoor fireplaces, island bars and grills, kitchens, tables, waterfalls, fire rings, seatwalls and pillars kits.

## Affordable luxury

Necessaries kits are both beautiful and functional, turning backyards into attractive and enjoyable outdoor living spaces. Also, Necessaries come ready-to-assemble with everything needed to build, making them easier to install and more affordable than typical masonry structures.

## Easy to build

Each Necessaries Outdoor Living Kit comes complete with everything you need to build, including precut block sized to fit, reinforcements, adhesive, and easy-to-read, step-by-step instructions. Most kits can be built by two people in an afternoon, or less.

## Expand anytime

You can build your project all at once or add new features over time. Because of Necessaries' modularity, expanding your outdoor living space is easy to do whenever you are ready.

## Earthy colors

Necessaries kits feature Rockwood Retaining Walls' multi-piece, tumbled Lakeland and Riverland wall systems in:

- Beechwood
- Bluestone
- Santa Fe



Necessaries caps/tops are wet cast reproductions of handcrafted limestone originals. All tops, hearths and mantels come in Indiana Limestone (gray).

## Standard features

- NO CUTTING
- Easy-to-read, step-by-step instructions
- Premium stainless steel grills and components
- Mantels, tops and caps are cast from Indiana limestone originals
- Concrete precut and reinforcements sized to fit
- VOC-compliant adhesive and gloves

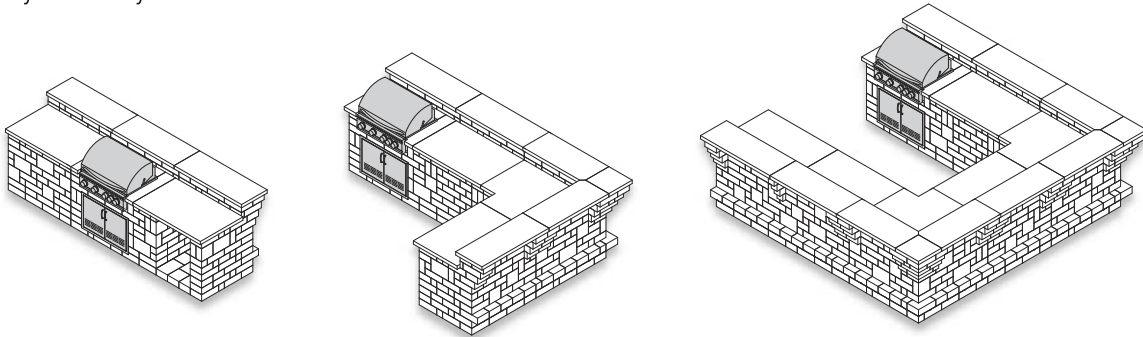

# Grand Fireplace Kits

Rockwood Retaining Walls

## Features

- Includes FMI Products 36" stainless steel, wood-burning insert, log rack and spark curtain. Adaptable for natural or LP gas.
- 4' stainless stovepipe chimney
- Spark suppressor cap
- Gas burner log set (optional)
- Optional **Grand Wood Box Kit** available left or right side
- Optional **Grand Hearth Kit**

**Colors:** Beechwood, Bluestone, Santa Fe

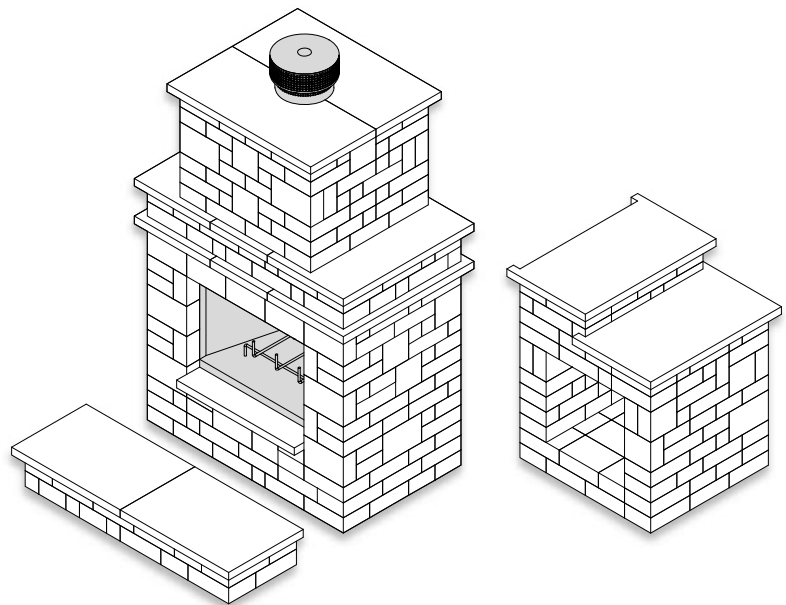

Grand Fireplace	Size	Pallets/Weight	Build Time
Fireplace (Interior: 33 W x 16 D x 19" H)	60 x 36 x 102" H	5 (9,677 lbs.)	8 hrs.
Hearth	60 x 20 x 10" H	1 (709 lbs.)	3 hrs.
Woodbox (Interior 24 W x 28 D x 24" H)	40 x 36 x 50" H	2 (4,061 lbs.)	1 hr.

Build time assumes two people with limited skills and base work is complete prior to construction. **Kits cannot be returned.**



# Colonial Fireplace Kit

Rockwood Retaining Walls

## Features

- 2.25" fire brick protects block
- Optional **Woodbox Kit** available left or right side
- Optional **Hearth Kit**
- **Gas Burning Option\***
  - NG or LP conversion kit, all connections and instructions
  - 2 burner, 52,000/49,000 max Btu's
  - 18" iron log rack
  - Arizona Weathered Oak ceramic log set

**Colors:** Beechwood, Bluestone, Santa Fe

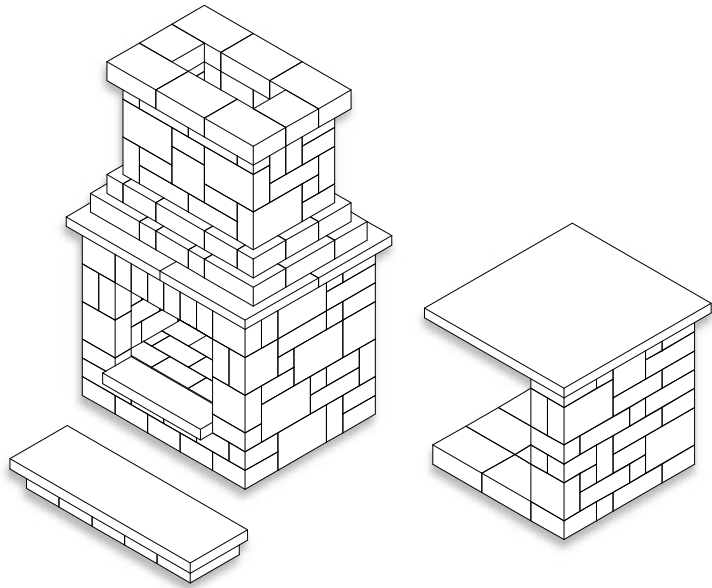

Colonial Fireplace	Size	Pallets/Weight	Build Time
Fireplace (Interior: 29 W x 18.5 D x 26.5" H)	40 x 32 x 70" H	2 (4,360 lbs.)	3 hrs.
Hearth	40 x 12 x 6" H	1 (295 lbs.)	0.5 hr.
Woodbox (Interior: 24 W x 24 D x 28" H)	32 x 32 x 34" H	1 (1,665 lbs.)	1 hrs.

# Compact Fireplace Kits

Rockwood Retaining Walls

## Features

- 2.25" fire brick protects block
- Optional **Woodbox Kit** available left or right side
- Optional **Hearth Kit**
- **Gas Burning Option\***
  - NG or LP conversion kit, all connections and instructions
  - 2 burner, 52,000/49,000 max Btu's
  - 18" iron log rack
  - Arizona Weathered Oak ceramic log set

**Colors:** Beechwood, Bluestone, Santa Fe

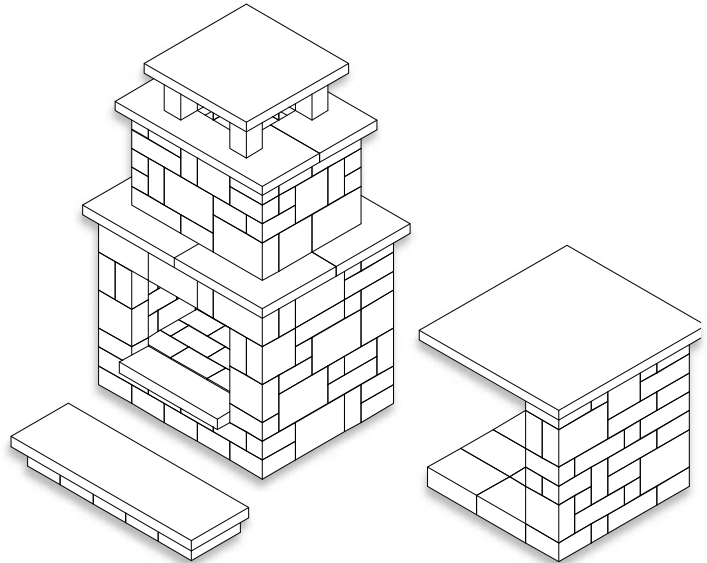

Compact Fireplace	Size	Pallets/Weight	Build Time
Fireplace (Interior: 29 W x 18.5 D x 26.5" H)	40 x 32 x 70" H	2 (3,735 lbs.)	3 hrs.
Hearth	40 x 12 x 6" H	1 (295 lbs.)	0.5 hr.
Woodbox (Interior: 24 W x 24 D x 28" H)	32 x 32 x 34" H	1 (1,665 lbs.)	1 hrs.

Build time assumes two people with limited skills and base work is complete prior to construction. **Kits cannot be returned.**

**Necessaries are easy to customize.**



# Victorian Fireplace Kits

Rockwood Retaining Walls

## Features

- 2.25" fire brick protects block
- Optional **Woodbox Kit** available left or right side
- Optional **Hearth Kit**
- **Gas Burning Option\***
  - NG or LP conversion kit, all connections and instructions
  - 2 burner, 52,000/49,000 max Btu's
  - 18" iron log rack
  - Weathered Oak ceramic log set

**Colors:** Beechwood, Bluestone, Santa Fe

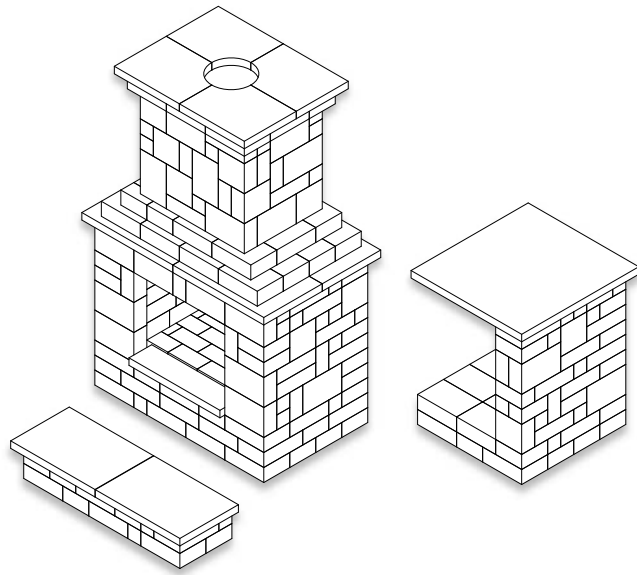

Victorian Fireplace	Size	Pallets/Weight	Build Time
Fireplace (Interior: 31 W x 17.5 D x 29.5" H)	52 x 32 x 89" H	5 (6,610 lbs.)	8 hrs.
Hearth	52 x 18 x 10" H	1 (580 lbs.)	1 hr.
Woodbox (Interior: 24 W x 24 D x 32" H)	32 x 32 x 42" H	2 (2,190 lbs.)	3 hrs.

Build time assumes two people with limited skills and base work is complete prior to construction. **Kits cannot be returned.**

# Seatwall and Pillar Kits

Rockwood Retaining Walls

## a. 20" Pillar Kit

- 2.25" H chiseled cap

## b. 20" Pillar with Glass Kit (lights not included)

- Pittsburgh Corning Premiere 8" glass block
- 2.25" H chiseled cap

## c. 24" Pillar Kit

- 2.25" H chiseled cap

## d. Lakeland Seatwall Kit

- Creates a 6' straight wall
- Optional chiseled cap

## e. Riverland Seatwall Kit

- Creates an 8' radius wall
- Optional chiseled cap

**Colors:** Beechwood, Bluestone, Santa Fe

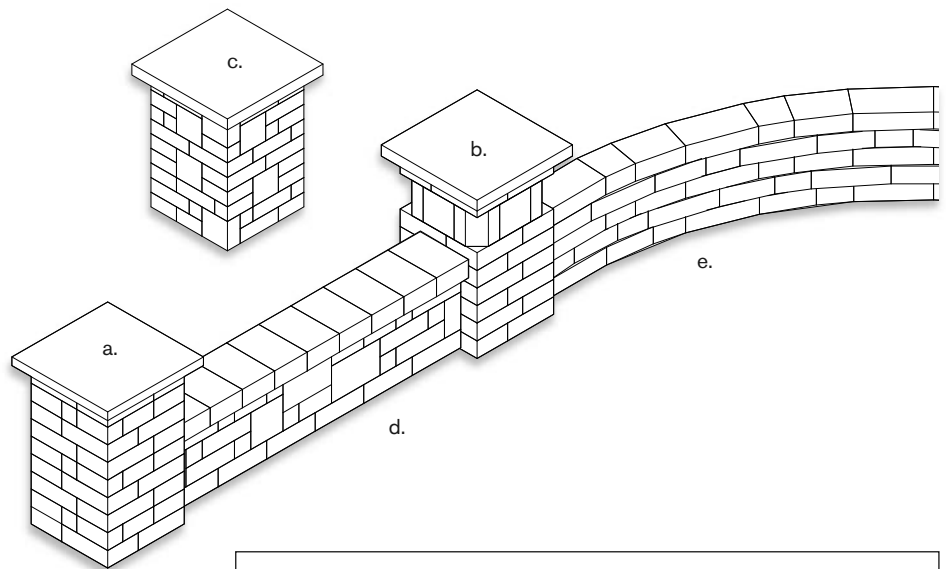

**(NEW) SPRING 2021**

**OUTDOOR LIVING KITS CAN BE ORDERED WITH OR WITHOUT TOPS. FIREPLACE KITS NOT INCLUDED.**

Kit	Size	Pallets/Weight	Build Time
20" Pillar Kit (w/25 x 25 x 2.25" top)	20 x 20 x 38" H	1 (1,260 lbs.)	0.5 hr.
20" Pillar w/Glass (w/25 x 25 x 2.25" top)	20 x 20 x 38" H	1 (1,150 lbs.)	0.5 hr.
24" Pillar Kit (w/30 x 30 x 2.25" top)	24 x 24 x 39" H	1 (1,665 lbs.)	0.5 hr.
Lakeland Seatwall Kit	72 x 8 x 20" H	1 (1,075 lbs.)	0.5 hr.
Riverland Seatwall Kit	108 x 8 x 20" H	1 (1,400 lbs.)	0.5 hr.

Build time assumes two people with limited skills and base work is complete prior to construction. **Kits cannot be returned.**



# Fire Rings Kits

## Rockwood Retaining Walls

### Grand Fire Ring Kit Features

- One-piece, heavy gauge, 48" D x 12" H  
Solid steel insert protects block (30.5" interior dia. x 8" H, 1.5" flang)
- Optional **Fire Ring Block Layer** – add layers to increase height
- Optional **Fire Ring Cap** – chiseled edge, eight-piece, in three colors, 2.25" H
- Optional **Swivel Cooking Grate** – removable, heavy steel construction, ADA compliant
- Optional **E-Z Access Spark Screen** – keep ash and sparks inside and debris out, hinged for easy access
- Optional **Cover** – heavy galvanized steel with or without cooking grate slot

**Colors:** Beechwood, Bluestone, Santa Fe, Onyx

### Grand Gas Fire Ring Kit (Not suitable for commercial installations)

- Push-button electronic ignition
- 65,000 max Btu/hr, natural gas or LP
- Thermo-couple auto shut-off safety feature
- #304 stainless steel construction
- All connections and fittings preassembled
- 50 lbs. lava rock
- Optional **Fire Ring Cap** – chiseled edge, eight-piece, in three colors, 2.25" H
- Optional **Arizona Weathered Oak Log Set**



**Colors:** Beechwood, Bluestone, Santa Fe, Onyx

### Victorian Fire Pit Kit Features

- Four-piece, heavy gauge, solid steel insert protects block
- Optional **Swivel Cooking Grate**

**Colors:** Beechwood, Bluestone, Onyx, Santa Fe

### Barn Plank Wall Fire Pit Kit Features

- Four-piece, heavy gauge, solid steel insert protects block
- Optional **Swivel Cooking Grate**

**Colors:** Mahogany, Weathered Gray

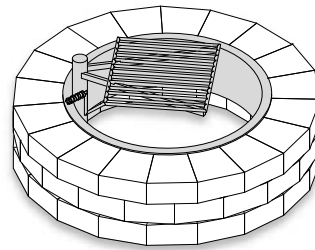

Grand Fire Ring

Grand Gas Fire Ring

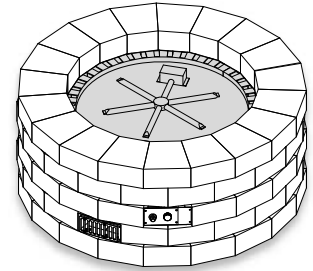

Victorian Fire Pit

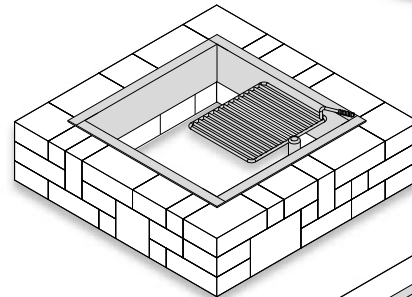

Barn Plank Wall Fire Pit

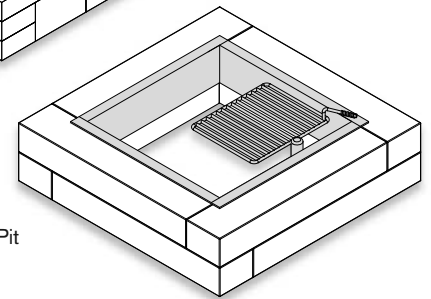

Kit	Size	Pallets/Weight	Build Time	Details
Grand (block only)	48 x 12" H	1 (1,019 lbs.)	0.5 hr.	Without steel insert
Grand Fire Ring	48 x 12" H	1 (1,057 lbs.)	0.5 hr.	With steel insert
Grand Fire Ring	48 x 12" H	1 (1,085 lbs.)	0.5 hr.	With insert and swivel cooking grate
Grand (one layer)	48 x 4" H	1 (346 lbs.)	-	19 Lakeland Fire Ring Block
Victorian Fire Pit (block only)	48" W x 12" H	1 (1,285 lbs.)	0.5 hr.	Without steel insert
Victorian Fire Pit	48" W x 12" H	1 (1,310 lbs.)	0.5 hr.	With insert and swivel Cooking Grate
Grand Gas Fire Ring	48 x 20" H	1 (1,710 lbs.)	0.5 hr.	Natural Gas
Barn Plank Wall Fire Pit	48 x 12" H	1 (1,255 lbs.)	0.5 hr.	With steel insert
Barn Plank Wall Fire Pit	48 x 12" H	1 (1,525 lbs.)	0.5 hr.	With steel insert and swivel cooking grate

Options/Accessories	Size	Weight	Details
Fire Ring Cap (Cannot be double stacked)	10 W x 2.25" H	298 lbs.	In Indiana Limestone, Bluestone, or Buff.
Grand Cover	37.9 dia. x 2.88" H	27 lbs.	Heavy galvanized steel
Grand Cover w/Slot	34.9 dia. x 1.88" H	27 lbs.	Heavy galvanized steel, slotted for swivel cooking grate
Grand Swivel Cooking Grate	19.25 x 17.5 x 2" H	10 lbs.	300 sq. in. ADA approved swivel cooking grate, removable
Grand Steel Ring Insert	33.5 x 33.5 x 8.5" H	34 lbs.	Solid 10-guage steel with 1" top lip, boxed
E-Z Access Spark Screen	40 x 18" H	22 lbs.	Hinged spark screen
LP Gas Conversion Kit			O-Ring conversion to LP
AZ Weathered Oak Gas Log Set	16" H	36 lbs.	9 pc. 16" height of log stack
Victorian Swivel Cooking Grate	19.25 x 17.5 x 2" H	10 lbs.	300 sq. in. ADA approved swivel cooking grate, removable
Victorian Steel Insert	33.5 x 33.5 x 8.5" H	34 lbs.	Solid 10-guage steel with 1" top lip, boxed

Build time assumes two people with limited skills and base work is complete prior to construction. **Kits cannot be returned.**

# Grand Island Bar Series

Rockwood Retaining Walls

## Features

### a) Grand Island Bar/Grill with Storage Kit\*

- Summerset Pro Sizzler 32" grill
- Stainless steel double doors - vented

### b) Grand Island Bar/Grill with Refrigerator Opening Kit\*

- Summerset Pro Sizzler 32" grill
- Stainless steel double doors - vented
- Optional Refrigerator (24" x 36" x 28" H opening)

See page 39 for Summerset Pro Sizzler grill features.

### c) Grand Island Bar 8' Kit

### d) Grill Surround Kit

- For standing grills, 60" opening

### e) Corner Return Kit\*\*\*

- Makes L-shaped bar/grill

### f) Bar Section 4' Kit\*\*

- Left or right facing

## Colors

- Beechwood
- Bluestone
- Santa Fe

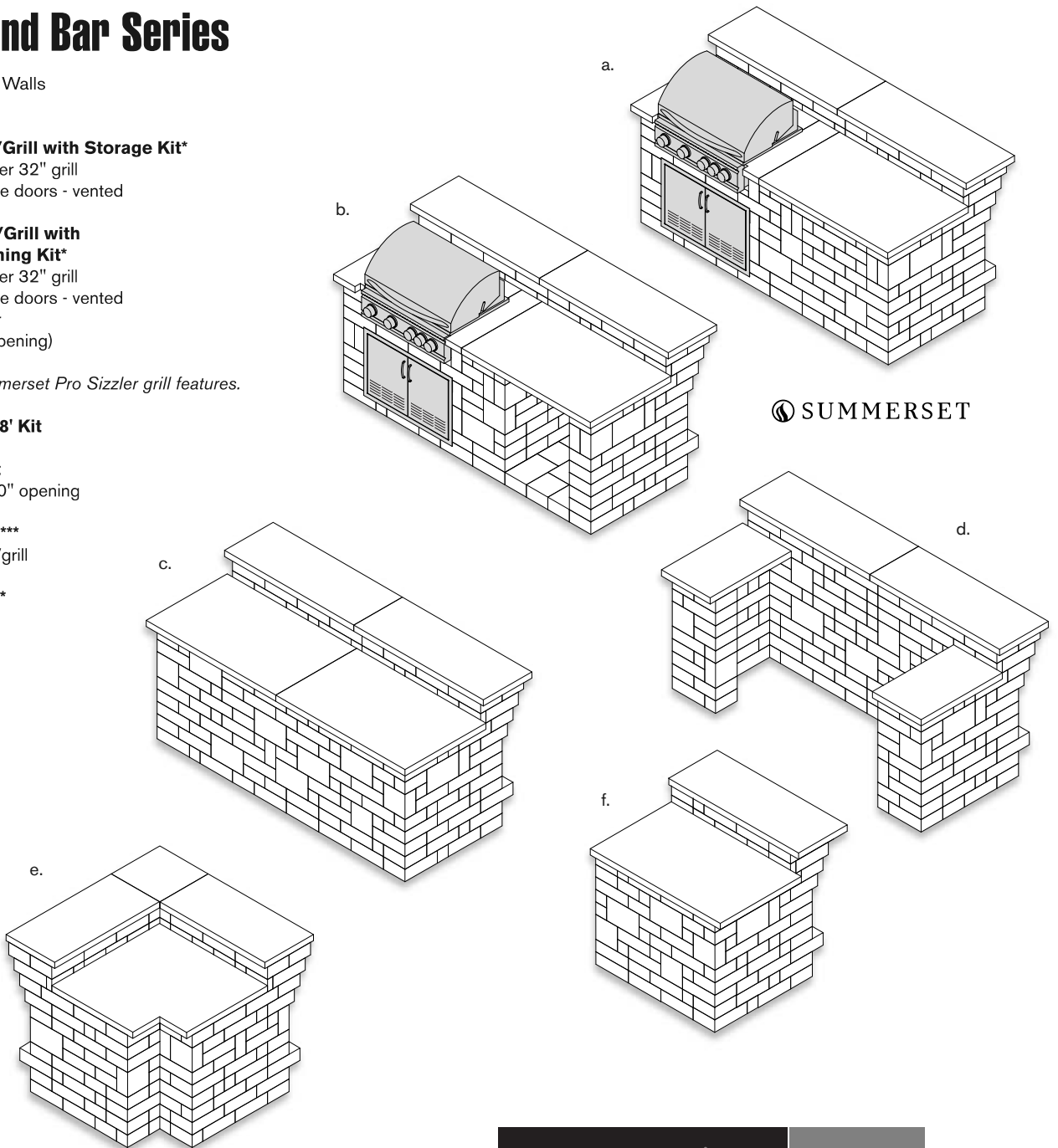

Name	Size	Pallets/Weight	Build Time	Details
Grand Island Bar	96 x 48 x 46" H	3 (7,271 lbs.)	6 hr.	
Grand Island Bar w/Grill & Storage*	96 x 48 x 46" H	4 (7,341 lbs.)	7 hr.	w/32" Pro Sizzler grill
Grand Island Bar w/Grill & Refrigerator Opening	96 x 48 x 46" H	4 (7,341 lbs.)	7 hr.	w/32" Pro Sizzler grill
Grand Island Grill Surround	96 x 48 x 46" H	2 (4,915 lbs.)	4 hr.	Fits 60" freestanding grill
Bar Section 4' Section**	48 x 48 x 46" H	1 (3,780 lbs.)	4 hr.	
Grand Island Bar Corner Return***	48 x 48 x 46" H	2 (5,140 lbs.)	6 hr.	

\*Please designate LP or NG grill at time of order. \*\* Must specify left side or right side when ordering.

\*\*\* Corner return edges are not finished, cannot use alone.

Build time assumes two people with limited skills and base work is complete prior to construction. **Kits cannot be returned.**

# Woodbox/Stand Kits

Rockwood Retaining Walls

**Colors:** Beechwood, Bluestone, Santa Fe

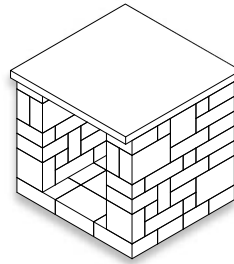

a) Silver Creek Top

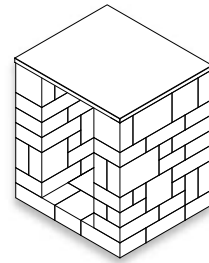

b) Granite Top

a) Silver Creek Top	36 x 32 x 34" H	1 Pallet: (7,271 lbs.)	Build Time: 1 hr.
b) Granite Top (Kitchen Kit)	32 x 28 x 37" H	1 Pallet: (1,830 lbs.)	Build Time: 1 hr.

# Waterfall Kits

Rockwood Retaining Walls

### Grand Waterfall Kit Features

- 1,350 gph mag drive pump
- 48" half-round basin
- 23" stainless steel spillway
- Optional LED light kit; blue or white

### Compact Waterfall Kit Features

- 850 gph mag drive pump
- 26" square basin
- 11" stainless steel spillway
- Optional LED light kit; blue or white

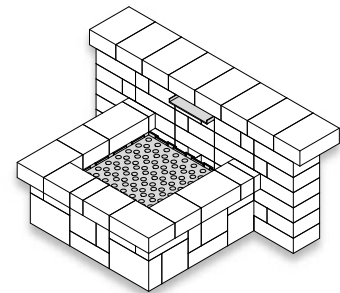
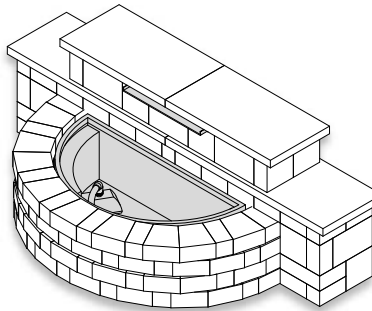

Waterfall kits include all plumbing/connections.

**Colors:** Beechwood, Bluestone, Santa Fe

Name	Size	Pallets/Weight	Build Time
Grand Water Feature	98" x 48" x 32" H	3 (3,475 lbs.)	4 hrs.
Compact Water Feature	64" x 40" x 28" H	1 (1,660 lbs.)	3 hrs.

Build time assumes two people with limited skills and base work is complete prior to construction. **Kits cannot be returned.**

# Bistro Table, Dining Table and Compact Bar Kits

Rockwood Retaining Walls

### Colors

- Beechwood
- Bluestone
- Santa Fe

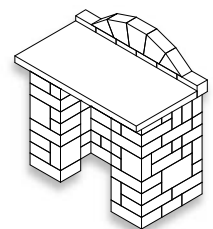
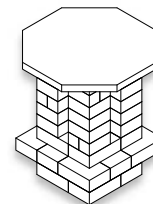
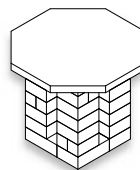
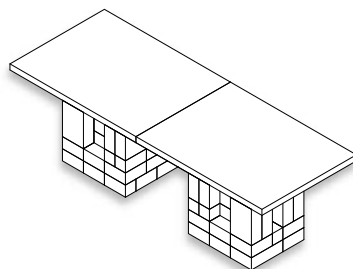

Name	Size	Pallets/Weight	Build Time	Details
Pub/Bistro Table	36 x 36 x 42" H	1 (1,515 lbs.)	1 hr.	Also builds 30" H Bistro Table
Compact Bar	48 x 24 x 38" H	1 (2,830 lbs.)	2 hrs.	Build open or closed front
Dining Table	36 x 96 x 30" H	1 (2,870 lbs.)	2 hrs.	Seats eight

Build time assumes two people with limited skills and base work is complete prior to construction. **Kits cannot be returned.**

All dimensions shown in inches.

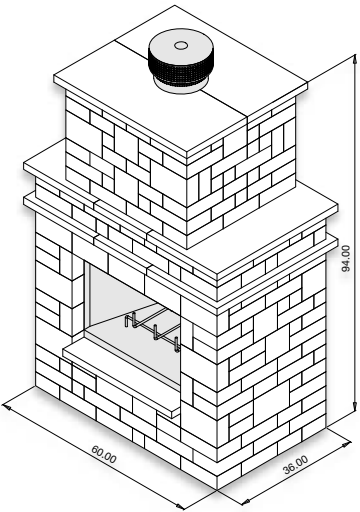

Grand Fireplace

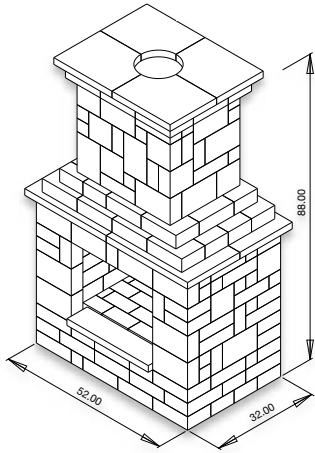
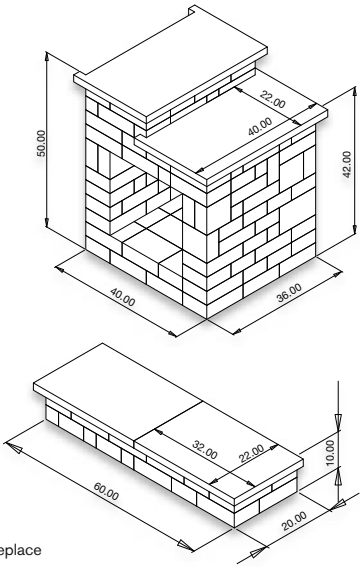

Victorian Fireplace

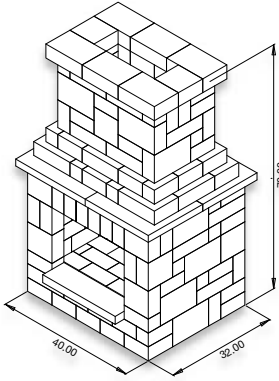
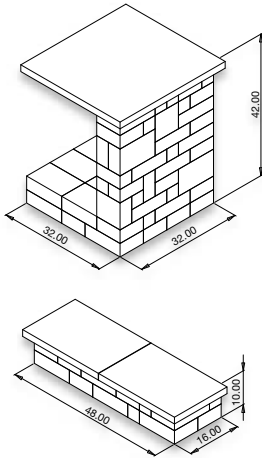

Colonial Fireplace

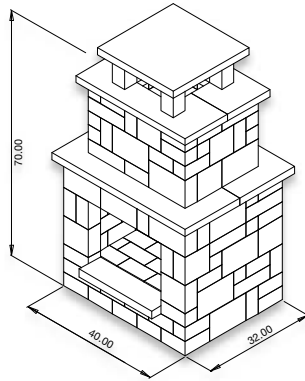
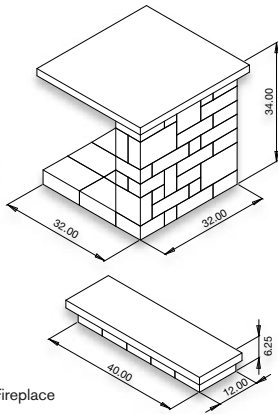

Compact Fireplace

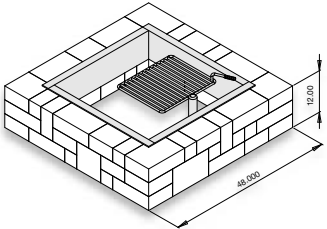
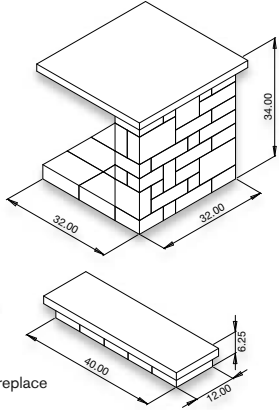

Victorian Fire Pit

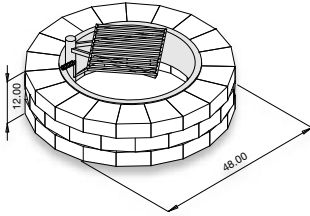

Grand Fire Ring

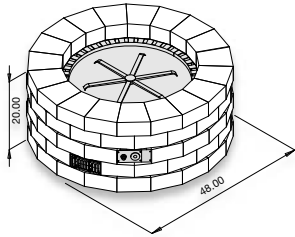

Grand Gas Fire Ring

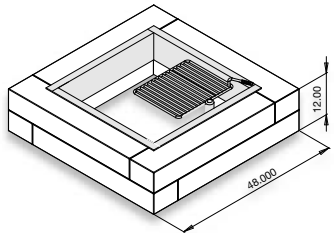

Barn Plank Wall Fire Pit

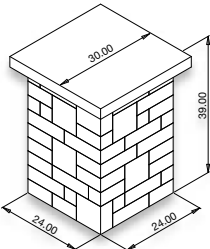

24 Pillar

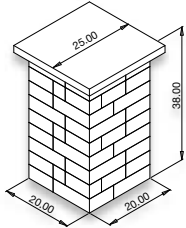

20 Pillar

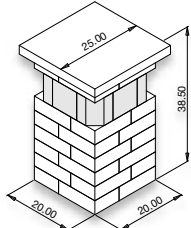

20 Pillar w/Glass



Kits are not suitable for commercial installations.  
All dimensions shown in inches.  
Features and specifications subject to change.

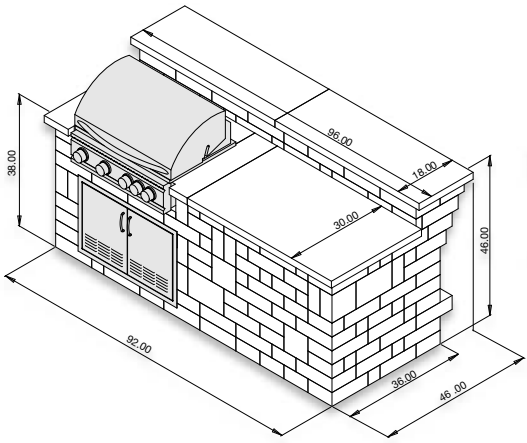

Grand Island Bar Grill

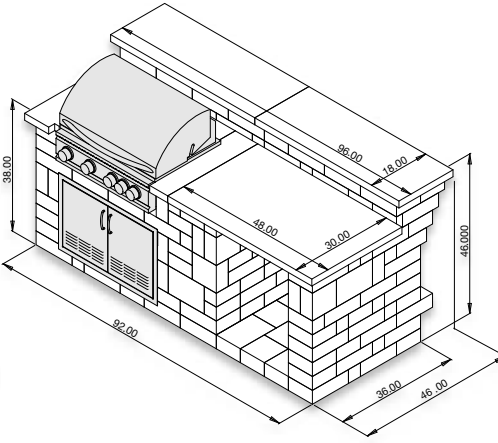

Grand Island Bar Grill w/Storage

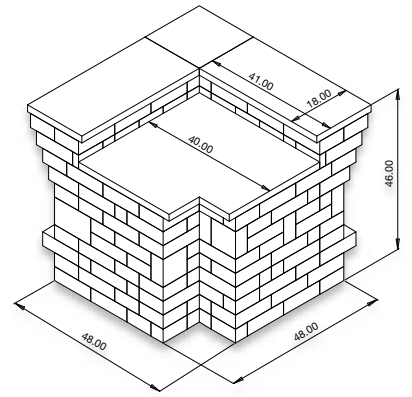

Grand Island Bar Corner Return

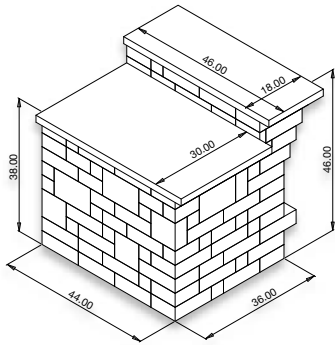

Grand Island Bar 4' Section

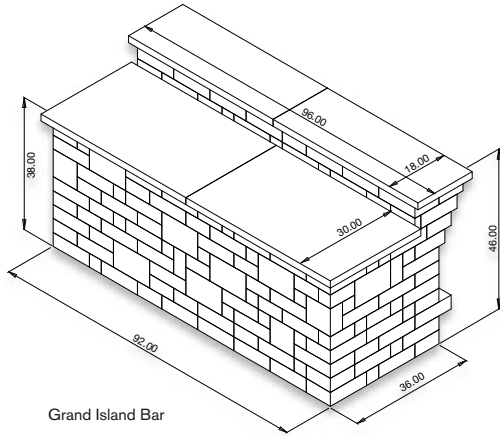

Grand Island Bar

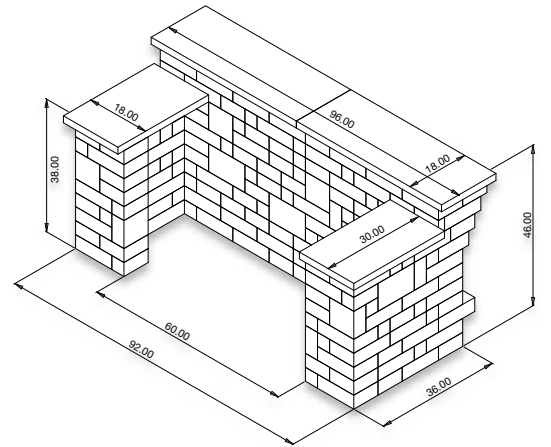

Grand Island Grill Surround

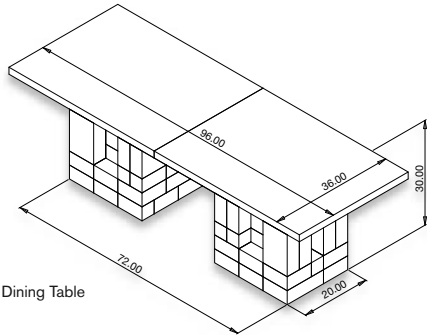

Dining Table

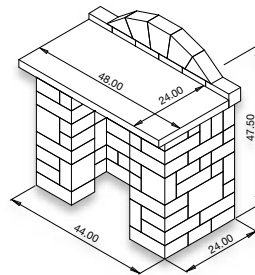

Compact Bar

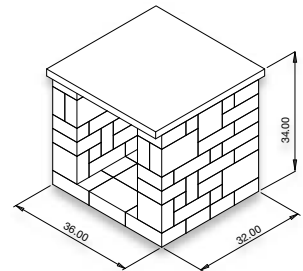

Woodbox Stand

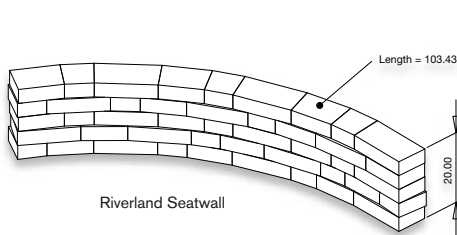

Riverland Seatwall

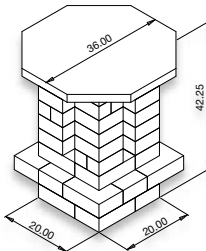

Pub/Bistro Table

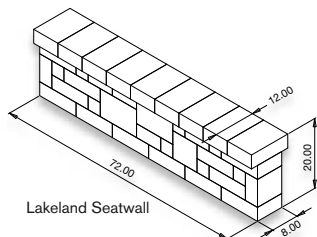
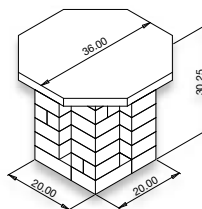

Lakeland Seatwall

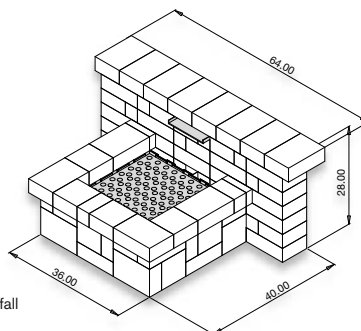

Compact Waterfall

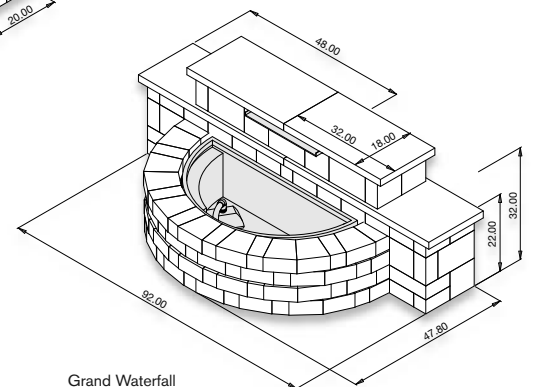

Grand Waterfall

# Calculating Paver Materials

Use the following methods to estimate the amount of materials you will need for your project.

## EXCAVATION DEPTH GUIDE

Gravel Base: Use minimum depths in a well-drained area or undisturbed soil. Use maximum depths in poorly drained area or disturbed soil. 1/2" less is required to compensate compacting of pavers. If soil is saturated more than 50% of the time, filter fabric and extra base should be used.

	Pedestrian Traffic	Light Vehicular Traffic
Pavers	2-3/8"	2-3/8"
Sand	1"	1"
Gravel Base (compacted)	4" - 6"	8" - 12"
Total Excavation Depth	7" - 9"	11" - 15"

---

## BASE MATERIAL CALCULATOR

### Granular Base:

Square Footage of Pavers x (depth of base ÷ 12) ÷ 27 = Cubic Yards of Base Needed

### Bedding Sand (1" depth):

Square Footage of Pavers x 0.0031 = Cubic Yards of Sand Needed

---

## EDGE RESTRAINT CALCULATOR

Length of restrained pavers (ft.) ÷ 8 = Pieces of SnapEdge

Note: Use one spike for every foot of retained pavers.

---

## CALCULATE BORDERS AND ACCENTS

Length of Border (ft.) ÷ Length of Product (ft.) = Number of units

Example: Cobble Stone Border

$$\frac{30}{\text{Length of Border (ft.)}} \div \frac{0.83}{\text{Length of Product (ft.)}} = \frac{36}{\text{Number of units}}$$

---

Discontinued products available  
until gone, call for availability.



# Calculating Retaining Wall Material Requirements

Use the following methods to estimate the amount of base material, drainage rock, and adhesive you will need for your project.

## BASE MATERIAL CALCULATOR

A typical trench is 2' wide and 14" deep to bury a full course of 8" block. Your base material must be a minimum of 6" in height.

$$\frac{\text{Wall Length in ft.}}{\text{Base Height in ft.}} \times \frac{\text{Base Width in ft.}}{27} = \text{Cubic Yards}^*$$

\*Add 10% for inconsistencies in the trench and compaction.

## DRAINAGE ROCK CALCULATOR

You need enough drainage rock to fill 1' behind the tail of the block and to fill any cores.

$$\frac{\text{Wall sq. ft.}}{1.33} \times 27 = \text{Cubic Yards}$$

## ADHESIVE CALCULATOR

The amount of adhesive required depends on type of block and construction. Use the guide below to estimate the amount of adhesive required.

Approximate length of bead by width:

Tube Size	Bead Widths/Tube		
	1/8"	1/4"	3/8"
10.5 oz.	129 ft.	32 ft.	14 ft.
29 oz.	355 ft.	89 ft.	39 ft.

Packaging	Tubes	
	10.5 oz.	29 oz.
Tubes/Case	12	12
Cases/Pallet	108	44

## ONLINE HARDSCAPES CALCULATOR

Quickly and easily calculate paver and materials requirements from your desktop or mobile device. Send yourself a PDF of the results for your project planning.

Go to: [www.rochestercp.com/estimator/](http://www.rochestercp.com/estimator/)

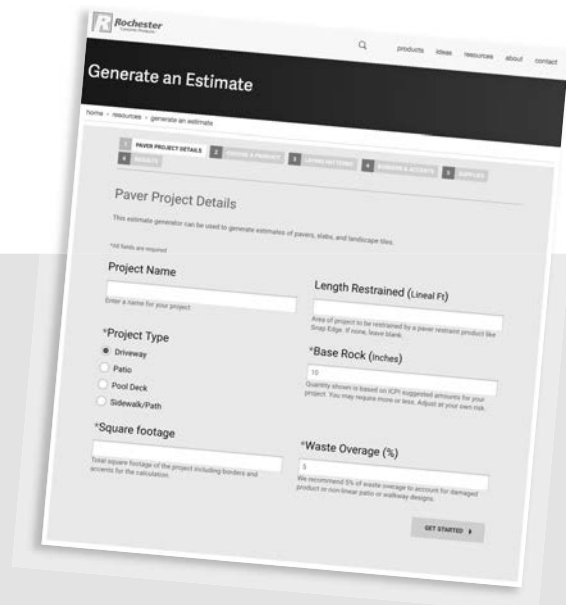

# Classic 6 & 8 Walls - 20" Pillar

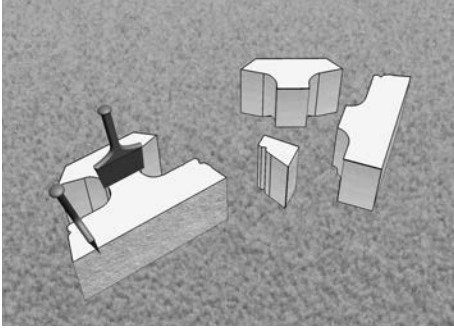

**Step 1 - Create a (Corner) Pillar Block**  
If you need to create corners on the job site, see instructions on previous page on how to create Corner Blocks.

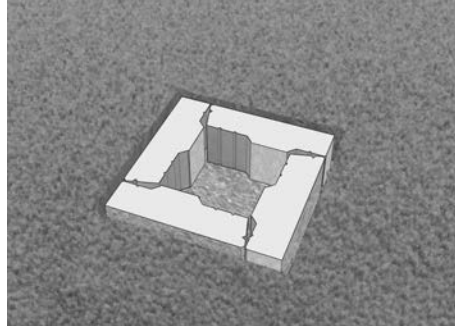

**Step 2 - Excavating and Site Preparation**  
Follow the steps for a leveling pad installation, as described in basic wall installation. Lay the first four pillar blocks with the split faces exposed to create the foundation for the 20" Pillar.

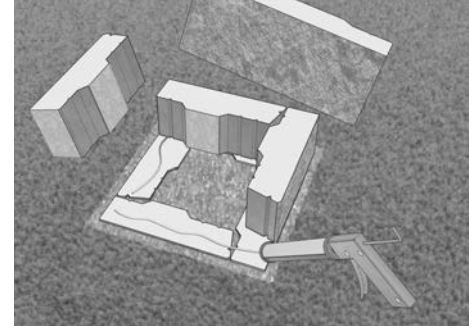

**Step 3 - Successive Course Installation**  
Stagger the pillar blocks so a running bond is maintained. Adhere all blocks with Super-Stik™.

# Classic 6 & 8 Walls - Half-Block Pillar

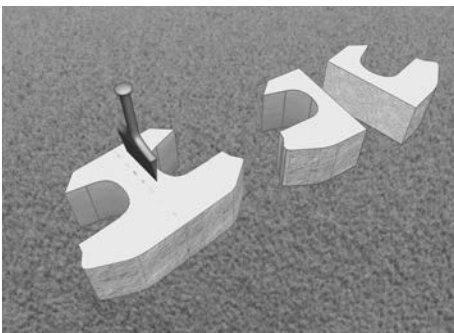

**Step 1 - Create a Half Block**  
If you need to create Half Blocks on the job site, be sure you have Base Block.

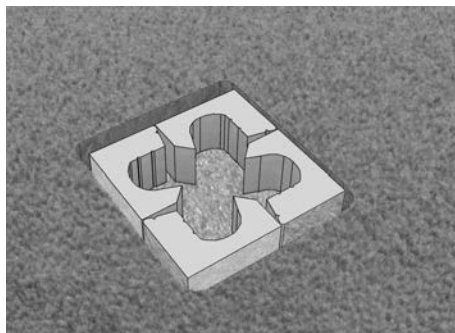

**Step 2 - Excavating and Site preparation**  
Follow the steps for a leveling pad installation, as described in basic wall installation. Lay the first four Half Blocks with the split faces exposed to create the foundation for the Half Block Pillar.

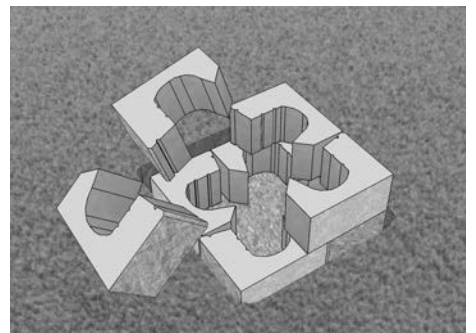

**Step 3 - Successive Course Installation**  
Stagger the Half Blocks so a running bond is maintained. Adhere all blocks with Super-Stik™.

# Classic 6 & 8 Walls - 90° Corners

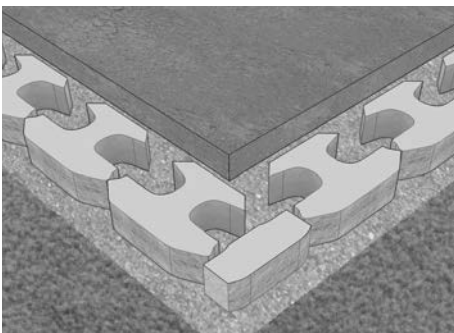

**Base Course Preparation with Corner Block**  
Begin an **outside corner** from the corner of the wall and install the blocks from the corner out when possible.

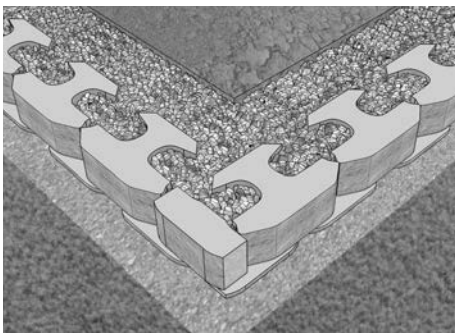

**Successive Course Installation**  
Stagger the Corner Block as each successive course is installed so it is on the opposite side of the wall corner. Length adjustments to the Corner Block may be necessary to maintain a running bond.

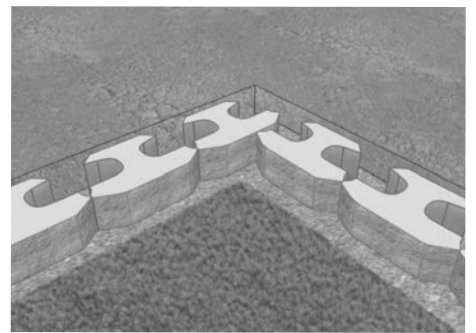

**Base Course Preparation**  
Begin an **inside corner** from the corner of the wall and install the blocks from the corner out when possible. Only half of a whole block installed on the corner will be exposed. This is true of each successive block that is staggered in the corner.



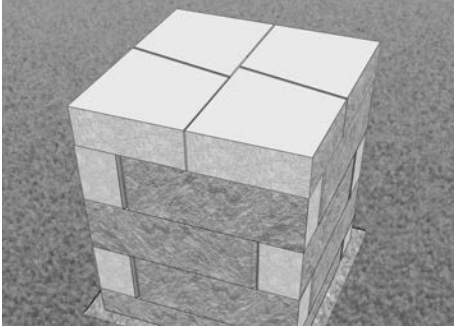

**Step 4 - Capping a 20" Pillar**

A 20" Pillar may be capped with Universal Caps, stone, or other prefabricated products. Adhere caps with Super-Stik™.

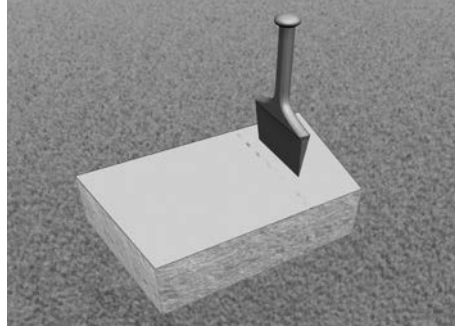

**Creating a Pillar Cap Block**

Pillars may be capped with 20" Universal Caps, stone or other prefabricated products. Adhere caps with Super-Stik™.

**ROCKWOOD®**  
 RETAINING WALLS  
*A better way.™*

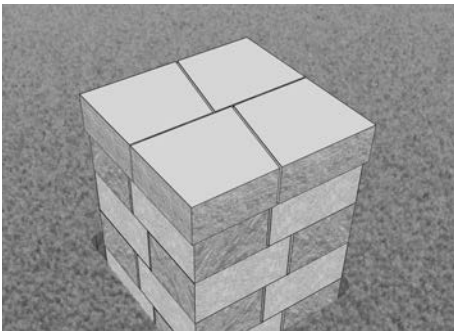

**Step 4 - Capping a Half Block Pillar**

A Half Block Pillar may be capped with Universal Caps, stone or other prefabricated products. Adhere caps with Super-Stik™.

**Adjusting Setback for Near Vertical Walls**

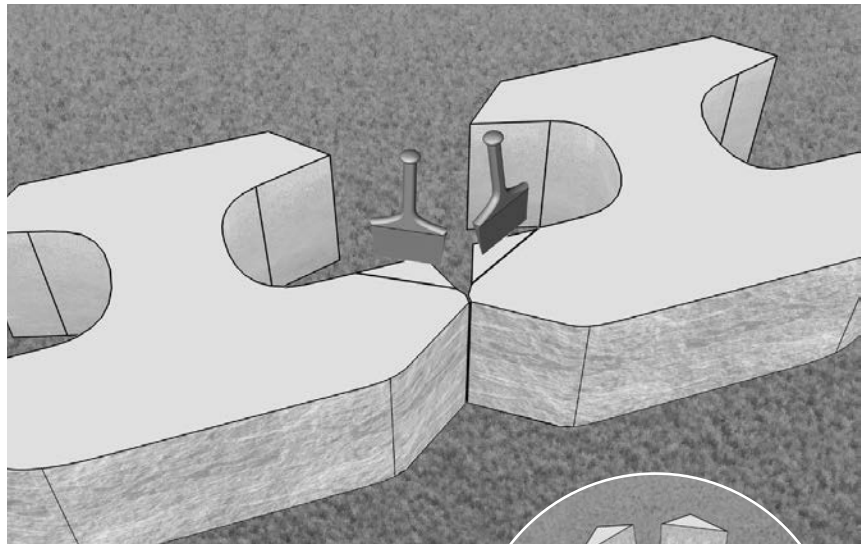

Rockwood blocks offer the unique ability to modify the facing batter of a wall. This is especially useful in stair step and egress window applications. For 6" tall Blocks, adjust setback by 3/4". For 8" tall Blocks, adjust setback by 1". The setback is determined by how much material is removed.

To adjust the setback, modify the two blocks below the successive course by splitting at the grooves on the top of each block. NEVER ALTER THE ANCHOR BAR! Doing so will adversely affect the performance of the wall.

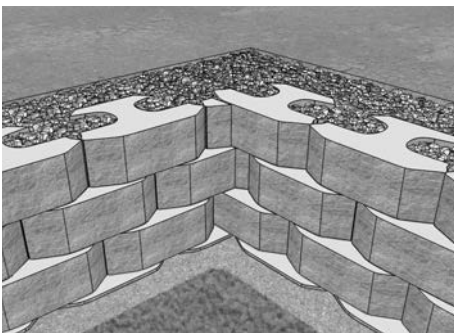

**Successive Course Installation**

Gaps will develop in successive courses, which will require a "wedge" block to fill the gap. Measure the gap and cut a block to fill the gap. Adhere cut block with Super-Stik™. Depending on the height of the wall, the "wedge" block will eventually become the same size as a whole block, then the process repeats itself.

**Note: For complete retaining wall installation instructions, request a copy of the manual for the block system you are building with.**

**Available online at: [www.rochesterpc.com/install](http://www.rochesterpc.com/install)**

## Classic 6 & 8 Walls - Half, Base and Corner Blocks

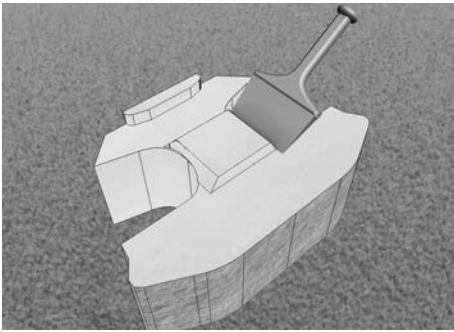

**To create a Base Block**, position the block so the Anchor Bar is facing up. Remove the Anchor Bar with a hammer and chisel as shown – wear protective equipment when modifying the block.

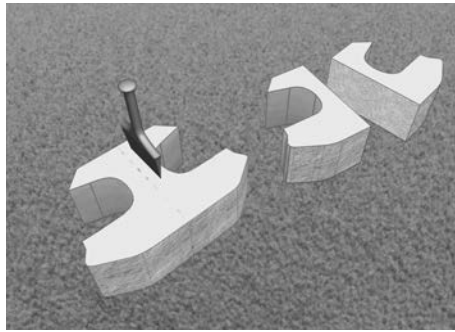

**To create a Half Block**, make a score line in the middle of the block, from front to back and on both sides. Split as shown. Wear protective equipment when splitting.

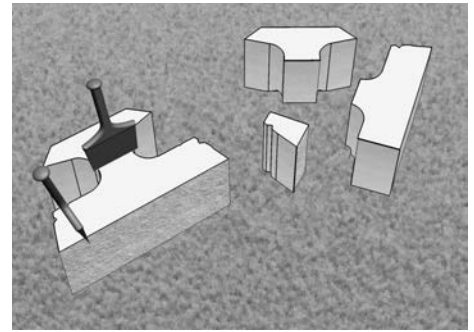

**To create a Corner Block**, make score lines on both splitting grooves and behind the head of the block. Split the block on both top and bottom sides, as shown. A hammer and chisel, or a hand splitter may be used to create the block. Wear protective equipment when splitting.

## Classic 6 & 8 Walls - Basic Installation

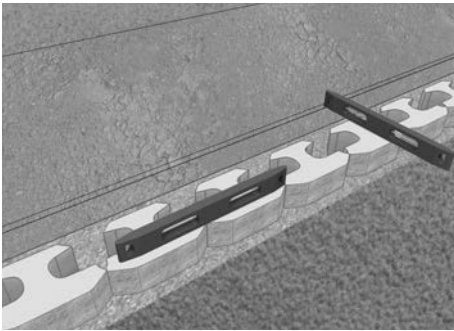

### Base Course Installation

The base course will consist of base block. Use a string line behind the tail of the block for alignment on straight wall applications. All blocks should rest firmly on the pad and be centered to allow 6" of base material in front and 6" behind the Base Block. Level each block, side-to-side, front-to-back and across three full blocks with a hand level. A rubber mallet may be used to level and align the blocks.

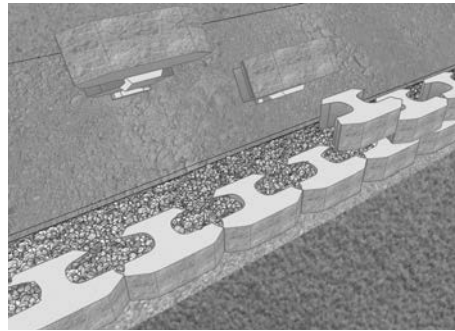

### Core and Drainage Fill

Place 3/4" to 1" clean aggregate (crushed rock) within the cores and a minimum of 12" behind the blocks. This creates a drainage zone and Stone Columns that helps to unify and maximize the performance of the wall.

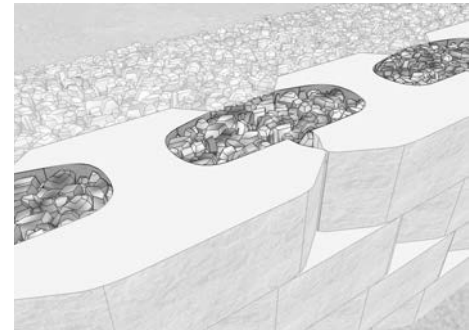

"Stone Columns" are an integral part of a Rockwood Retaining wall; adding support and stability to the wall.

## Classic 6 & 8 Walls - Stepping a Wall

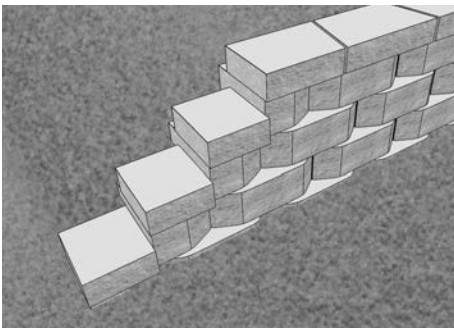

A Half Block or Corner Block may be used to end a course in a Rockwood application.

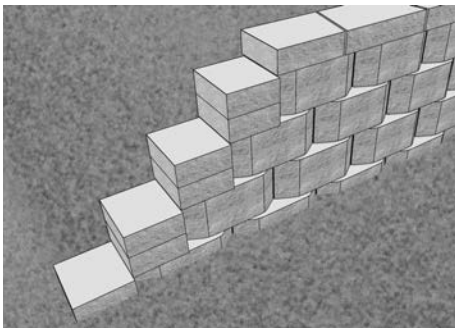

Double stack 4" tall Universal Caps as an end cap to finish courses of 8" tall blocks.

**ROCKWOOD**<sup>®</sup>  
RETAINING WALLS  
*A better way.™*

# Vintage 6 Wall - Basic Installation

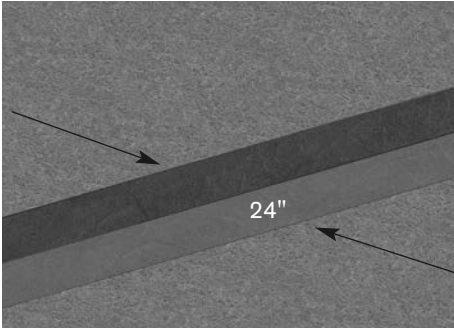

Note: Vintage 6 Garden Walls may be built to a maximum total height of 36" (under ideal conditions) without geogrid. Use a minimum 6" embedment and 12" of clean crushed rock behind wall.

## Step 1 - Base Course Preparation

Beginning at the wall's lowest elevation, excavate a trench down the length of the wall with a minimum width of 24" to accommodate at least 6" of base material and 6" of block embedment. As a rule of thumb, for every 8" to 10" of wall height, 1" of block should be buried with a minimum of 6" base course embedment. Step the trench up or down with respect to adjacent grade.

## Step 2 - Leveling Pad Installation

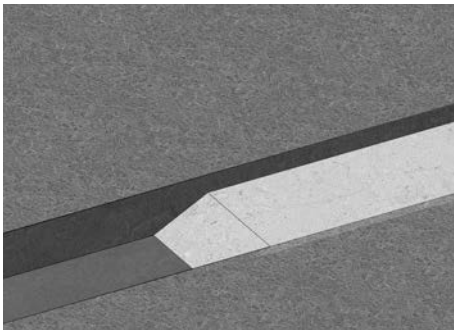

Note: Unlike other wall systems, Vintage builds vertically with no setback. For this reason, take extra caution to make sure the first course is level from front to back to prevent tipping or overturning.

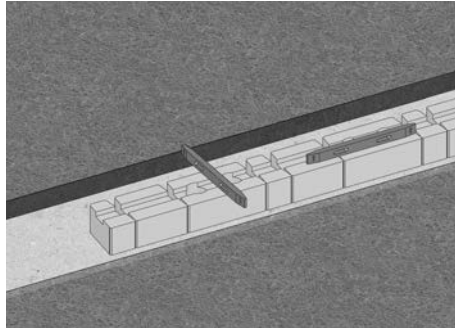

## Step 3 - Base Course Installation

The base course will consist of Vintage all three blocks. Use a string line for alignment on straight wall applications. All blocks should rest firmly on the pad and be centered on the base to allow approximately 6" of base area in front and behind the block. Level each block side-to-side, front-to-back, and across three blocks with a hand level. A rubber mallet may be used to level and align the Vintage blocks.

Note: For best alignment results on straight walls use the string line within the interlocking channel.

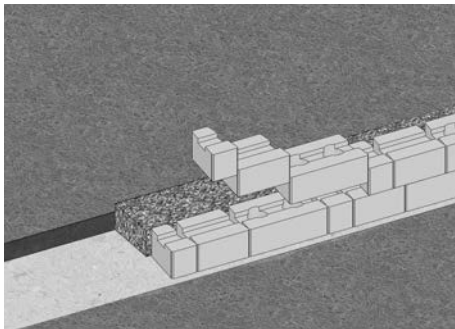

## Step 4 - Drainage Fill

Place 3/4" to 1" clean aggregate (crushed rock) a minimum of 12" behind the blocks. This creates a drainage zone that helps to unify and maximize the performance of the wall.

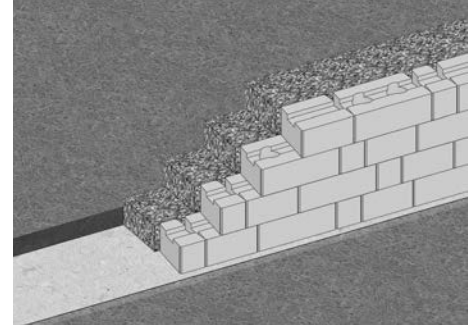

## Step 5 - Continue to build courses

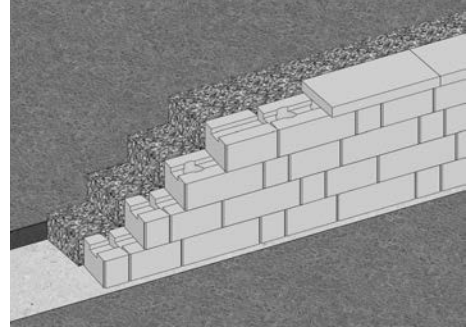

## Capping a Wall

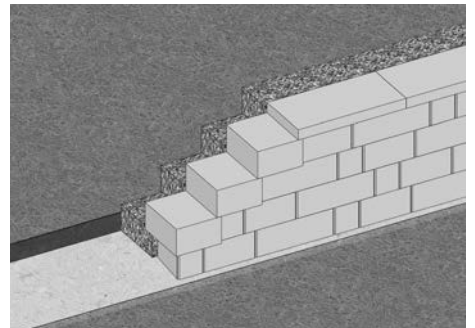

**Ending a Wall** - Step the end of your exposed wall with Vintage 6 corner block.

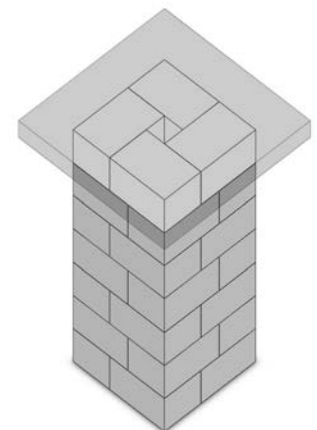
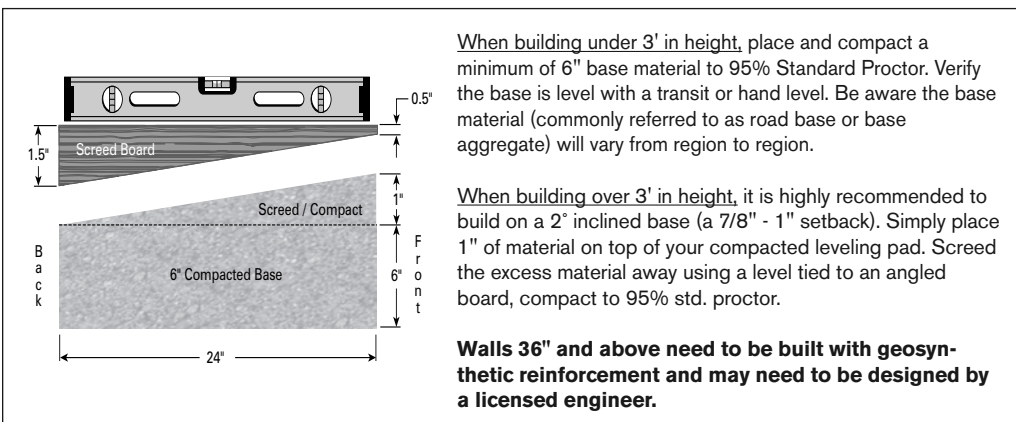

One Vintage Pillar/Corner pallet (12 x 9 x 6" H) can build a 42" H pillar with 28 units.



# Vintage 6 Wall - Basic Installation

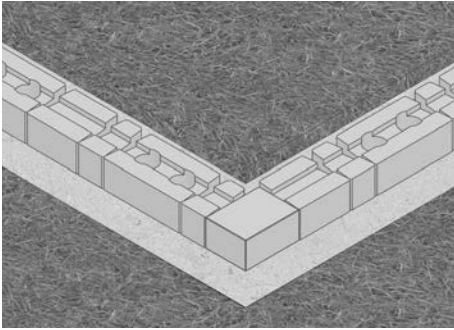

90° Outside Corner Base Course

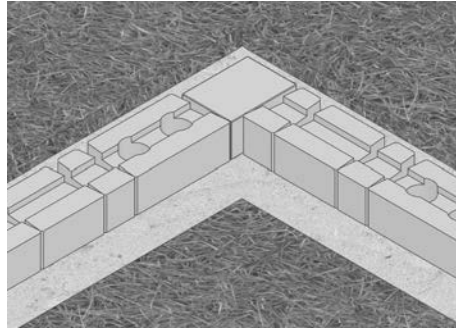

90° Inside Corner Base Course

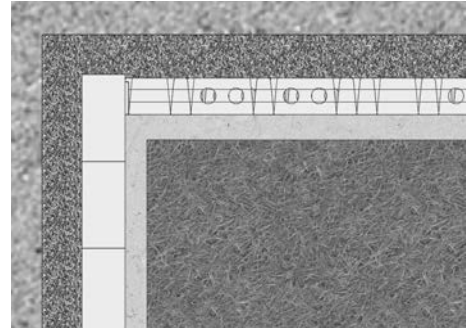

Capping a 90° inside corner

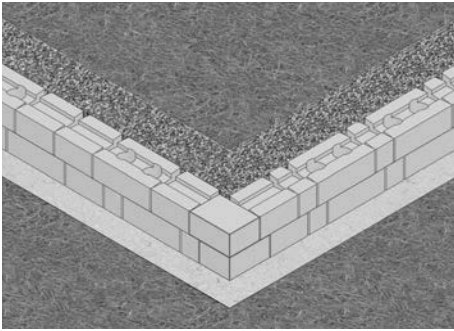

90° Outside Corner Second Course

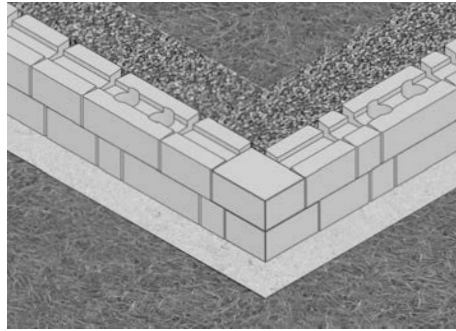

90° Inside Corner Second Course

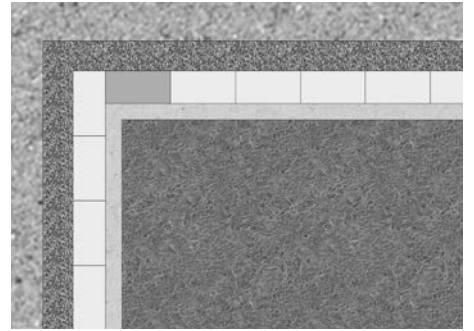

Capping a 90° inside corner

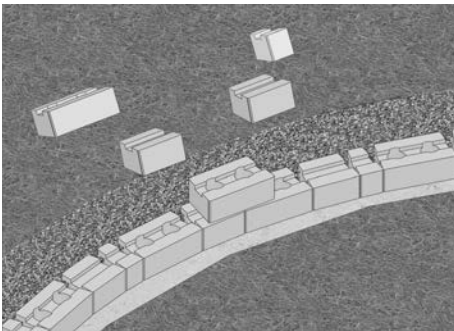

Building a Concave Curve

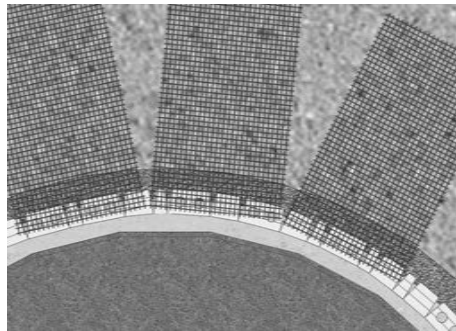

Reinforcing a Concave Curve

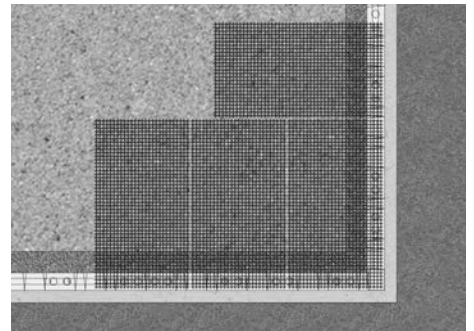

Reinforcing a 90° Outside Corner

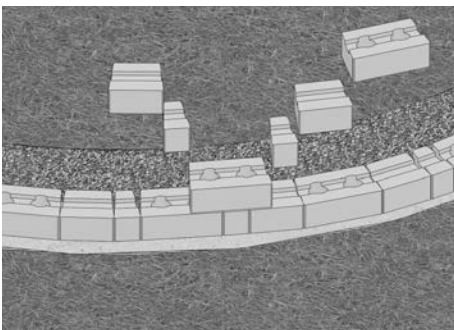

Building a Convex Curve

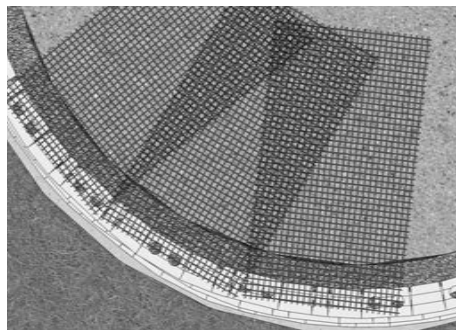

Reinforcing a Convex Curve

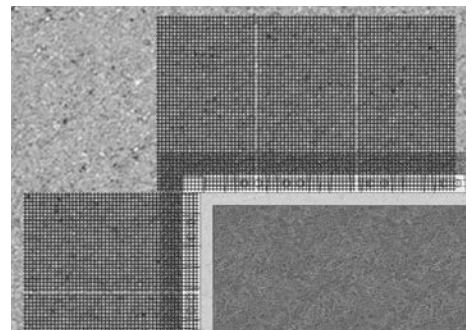

Reinforcing a 90° Inside Corner

*A better way.™*

**PLEASE NOTE:** Garden walls designs above 36" and retaining walls of any height that support a load should be evaluated and approved by a qualified professional engineer.

For complete retaining wall installation instructions, request a copy of the manual for the block system you are building with. Available online at: [www.rochesterpc.com/install](http://www.rochesterpc.com/install)

# General Terms and Conditions of Sale

These General Terms and Conditions of Sale (these "Terms and Conditions") will apply to the sale of goods and any (if any) applicable services (collectively, with any such services, being the "Goods") pursuant to any contract (a "Contract") to which these Terms and Conditions are made applicable. As used in these Terms and Conditions, "we," "us," "our" and similar terms refer to Rochester Concrete Products, LLC, and "Customer" means the party purchasing the Goods from us.

**Alteration.** No provision in these Terms and Conditions may be varied or waived except by a writing signed by us specifically referring to these Terms and Conditions and describing such variance or waiver. Our acceptance or acknowledgment of Customer's purchase order or any other document pertaining to the Goods, even if in writing and signed by us, will not be deemed an acceptance of any provision of Customer's purchase order or any other document that conflicts with or adds to these Terms and Conditions, absent a separate agreement in writing signed by us expressly acknowledging and agreeing to such provisions. Without limiting the generality of the foregoing, we object to any different or additional terms or conditions contained in any request for quotation, purchase order or other document of Customer, and no such terms will be effective or binding upon us unless we agree to such terms in a writing signed by one of our officers. In no event will our delivery of any Goods be an assent to any such terms proposed by Customer. Unless otherwise expressly stated in any applicable quotation or comparable document signed by us, we may revoke any quotation or other offer at any time prior to acceptance, and no such quotation or other offer will be valid for more than 30 days. After acceptance of an order, Customer may not cancel or terminate any Contract without our consent, except as provided herein or by applicable law.

**Payment; Delivery.** All prices are quoted and all payments will be made in U.S. Dollars. Customer will pay our invoices IN FULL on the terms stated in the applicable invoice, without set-off or counterclaim. Past due invoices will bear a late fee of 1.0% per month or, if less, the highest rate permitted by applicable law. Any stated shipment or delivery date is the date on which we in good faith believe the Goods will be shipped, but failure to ship on that date will not be a breach of the Contract, whether such Goods are in fact shipped before or after that date. All Goods are shipped Ex Works (Incoterms 2010) at our facilities, and costs of transportation and risk of loss during shipment will be borne by Customer. We may deliver any Goods hereunder in installments, in which case each installment will be treated as a separate sale hereunder and may be separately invoiced. Customer will pay all duties and sales, value-added, excise, use or other taxes arising in connection with any transaction (other than taxes based solely on our taxable income). Unless otherwise specified, Goods will be shipped in packaging we reasonably select.

**Duty to Inspect.** Customer will inspect all Goods promptly upon delivery and notify us promptly upon becoming aware of any non-conformity to the Contract. Except as stated regarding any applicable written warranty, we will have no liability regarding any such non-conformity unless such notice is given to us no later than (i) for a defect that could be determined by inspection upon delivery, the 30th day after delivery of such Goods, or (ii) for any other defect, the 30th day after such defect should reasonably have been discovered by Customer, but in each event not later than the 60th day after delivery of the Goods to Customer. Shipments less than 5% over or under the quantity specified in the Contract will be deemed in conformance with the Contract. Goods will not be deemed

non-conforming solely by reason of minor modifications or changes in materials from those specified in the Contract, so long as such modifications and changes do not materially and adversely affect the performance of the Goods. If the Goods do not conform to the Contract, our obligation will be limited to, at our election, supplying the missing Goods, replacing the relevant Goods, or refunding the purchase price paid for such Goods (but in all cases as otherwise may be limited in any other Paragraph of these Terms and Conditions or the Contract).

**Security Interest.** We reserve, and Customer hereby grants to us, a security interest in all Goods. That security interest secures all present and future obligations of Customer to us, including but not limited to the obligation to pay the price of the Goods. We may make any such filings as reasonably necessary to perfect such security interest (and Customer will cooperate promptly in all reasonable respects in connection therewith).

**Our Warranty.** Customer will ensure that any written warranty that we provide with the Goods is properly given to the end user of the Goods (whether by providing such warranty directly or causing Customer's contractors to do so).

**Limited Warranty.** We make no warranty of any nature whatsoever with respect to the Goods, other than any written, limited warranty that we may provide at the time we provide the Goods. If Customer discovers any breach of or similar creation of obligation under the warranty described above, Customer must notify us in writing thereof within 30 days after such discovery. Within a reasonable time following such notification, we will determine whether such warranty in fact applies and will, at our option, either (i) repair or replace the applicable Goods, (ii) remit to Customer the purchase price paid for such Goods, or (iii) take any other action consistent with the terms of such warranty. THE FOREGOING WARRANTIES ARE EXCLUSIVE. WE MAKE NO OTHER WARRANTY, EXPRESS OR IMPLIED, INCLUDING BUT NOT LIMITED TO ANY IMPLIED WARRANTY OF MERCHANTABILITY, NON-INFRINGEMENT OR FITNESS FOR A PARTICULAR PURPOSE. THE REMEDIES SET FORTH IN THIS PARAGRAPH ARE THE EXCLUSIVE REMEDY FOR ANY BREACH OF OR SIMILAR CREATION OF OBLIGATION UNDER WARRANTY. The remedies set forth in this Paragraph will not be deemed to have failed of their essential purpose so long as we are willing and able to provide one of the applicable remedies set forth herein.

**Limitations.** WITHOUT LIMITING ANY OTHER LIMITATION OF LIABILITY, IN NO EVENT WILL WE BE LIABLE FOR ANY INCIDENTAL, INDIRECT OR CONSEQUENTIAL DAMAGES OF ANY KIND, WHETHER FOR BREACH OF ANY WARRANTY, BREACH OR REPUDIATION OF ANY OTHER TERM OR CONDITION, NEGLIGENCE, STRICT LIABILITY, OR OTHERWISE. IN NO EVENT WILL OUR AGGREGATE LIABILITY TO, THROUGH OR ON BEHALF OF CUSTOMER IN ANY WAY RELATED TO THIS OR ANY RELATED TRANSACTION EXCEED THE TOTAL AMOUNT PAID TO US UNDER THE APPLICABLE CONTRACT.

**Force Majeure.** We will not be liable for any failure to manufacture, deliver or provide, or for any delay in the manufacture, delivery or provision of, any Goods if such failure or delay is caused by act of God, fire, strike, blackout, labor difficulty, riot, inability to obtain raw materials, supplies or other goods or services, equipment, labor or transportation, governmental restrictions, public health nuisance, or similar cause over

which we are unable to exercise adequate control. We may cancel any Contract by notice to Customer if we determine in good faith that any such cause makes performance of the Contract impossible or commercially impracticable for us.

**Confidential Information.** "Confidential Information" means information that you obtain from or regarding us regarding our products, business practices, customers, assets or other matters, excluding any information that is publicly available when provided or thereafter becomes publicly available, other than by reason of your breach hereof. You will (i) not use any Confidential Information other than for the performance of any Contract, (ii) not disclose Confidential Information, except to your employees and contractors requiring such information for the performance of any Contract, (iii) use your best efforts to prevent your employees, your contractors, and your contractors' employees from using or disclosing Confidential Information to any party, except as permitted by this Paragraph, and (iv) return all Confidential Information to us upon our request following completion or termination of any Contract. This Paragraph (and all related rights and remedies) will survive performance or termination of any Contract.

**Miscellaneous.** All rights and obligations under these Terms and Conditions and any Contract will be governed by the laws of the State of Minnesota (without regard to principles of conflicts of law). The headings herein are for convenience of reference only and will not affect any meaning or interpretation. The United Nations Convention on Contracts for the International Sale of Goods will not apply. CUSTOMER HEREBY IRREVOCABLY SUBMITS TO THE EXCLUSIVE JURISDICTION OF ANY COURT SITTING IN HENNEPIN COUNTY, MINNESOTA, IN ANY PROCEEDING ARISING OUT OF OR RELATING TO THE INTERACTIONS BETWEEN US AND CUSTOMER AND TO THE RESPECTIVE COURT TO WHICH AN APPEAL OF THE DECISIONS OF ANY SUCH COURT MAY BE TAKEN, AND CUSTOMER AGREES NOT TO COMMENCE, OR COOPERATE IN OR ENCOURAGE THE COMMENCEMENT OF, ANY SUCH PROCEEDING, EXCEPT IN SUCH A COURT. CUSTOMER HEREBY IRREVOCABLY WAIVES, TO THE FULLEST EXTENT IT MAY DO SO, THE DEFENSE OF AN INCONVENIENT FORUM TO THE MAINTENANCE THEREIN OF SUCH A PROCEEDING. CUSTOMER HEREBY AGREES THAT A FINAL JUDGMENT IN ANY SUCH PROCEEDING WILL BE CONCLUSIVE AND MAY BE ENFORCED IN ANY JURISDICTION BY SUIT ON THE JUDGMENT OR BY ANY OTHER MANNER PROVIDED BY APPLICABLE LAW. CUSTOMER HEREBY EXPRESSLY WAIVES ANY RIGHT IT MAY HAVE TO A JURY TRIAL IN ANY SUCH PROCEEDING. NO CLAIM OR ACTION, REGARDLESS OF FORM, ARISING OUT OF THE INTERACTIONS BETWEEN US AND CUSTOMER MAY BE BROUGHT BY OR ON BEHALF OF CUSTOMER MORE THAN ONE YEAR AFTER THE CAUSE OF ACTION HAS ACCRUED (SUBJECT TO ANY FURTHER APPLICABLE LIMITATION). IF ANY SUCH LEGAL ACTION IS BROUGHT, THE PREVAILING PARTY WILL BE AWARDED REASONABLE ATTORNEYS' FEES IN ADDITION TO ANY OTHER RELIEF THAT MAY BE GRANTED.  
Version 3/20/13

# RCP, LLC Limited Lifetime Warranty

Congratulations on choosing Rochester Concrete Products, LLC ("RCP") products to protect and beautify your home. These superior-quality hardscape products have been designed to give you years of enjoyment and comfort.

**IMPORTANT NOTICE:** Read this entire RCP Limited Lifetime Warranty and Limitation of Liability ("Limited Warranty"). It is important that the warranted products be properly installed and maintained in order for them to function successfully throughout the duration of this Limited Warranty. Depending on the product's application, installation guides can be found at [www.rochesterpc.com](http://www.rochesterpc.com). It is also important for your installer to carefully review the technical information, including specifications, for the chosen use of your RCP products as it may be the responsibility of the installer or design engineer to provide independent soil testing, quality assurance inspection, testing, and design services necessary to insure a safe and functional application.

This Limited Warranty applies only to RCP products that are purchased and used as part of Rockwood Retaining Wall Systems installed in owner-occupied single-family homes within the United States, subject to the stated conditions and limitations. This Limited Warranty does not extend to any current or future products distributed, but not manufactured, by RCP. This Limited Warranty applies only to RCP's products and not to the system into which they may be placed. Nor does this Limited Warranty cover to RCP products used in governmental, commercial, or multi-residential applications.

**LIMITED LIFETIME WARRANTY FOR RCP PRODUCTS INSTALLED IN OWNER-OCCUPIED SINGLE-FAMILY HOMES AS A PART OF A ROCKWOOD WALL OR HARDSCAPE SYSTEM.** RCP warrants that its products will be free from defects for as long as you own your home. If RCP is given prompt notice of a defect, it shall, at its sole option: (1) repair or replace the defective product(s), or (2) refund the original purchase price of the defective product(s). This Limited Lifetime Warranty is provided only to the owner(s) of the home at the time of purchase and may not be assigned or transferred. In the event the owner(s) sells the home, this warranty automatically converts to a two-year limited warranty affording the same scope of protection and governed by the same conditions, disclaimers and limitations of this Limited Lifetime Warranty. If RCP elects to repair the defect, it shall be responsible for the labor to accomplish the repair. If RCP elects to replace the defective product(s), its obligation is to deliver suitable replacement product to owner's property.

## LIMITATION OF LIABILITY

This Limited Warranty sets forth the maximum liability for our products. **IN NO EVENT (INCLUDING WHERE THIS LIMITED WARRANTY IS DEEMED NOT TO APPLY TO THE SALE OR PRODUCT IN QUESTION) SHALL RCP, GLS INDUSTRIES, INC., OR ROCKWOOD RETAINING WALLS, INC. BE LIABLE FOR ANY INCIDENTAL, CONSEQUENTIAL OR SPECIAL DAMAGES RESULTING FROM THE SALE, INSTALLATION OR USE OF ANY RCP PRODUCTS.** Some states do not allow the exclusion or limitation of incidental or consequential damages for consumers, so the above limitation or exclusion may not apply to you.

## LIMITATION OF WARRANTY

RCP MAKES NO OTHER WARRANTIES, EXPRESS OR IMPLIED, INCLUDING ANY IMPLIED WARRANTIES FOR MERCHANTABILITY, FITNESS FOR A PARTICULAR PURPOSE OR OTHERWISE.

## DISCLAIMER – WHAT THIS LIMITED WARRANTY DOES NOT COVER

RCP is not responsible for or makes no warranty as to:

1. Product failure, loss or damage due to:
  - Normal wear and tear;
  - Damage due to improper handling and repeated or extended contact with chemicals, such as deicers;
  - Products improperly installed or maintained;
  - Acts of God;
  - Structural settlement, movement or vibration;
  - Products that have not been paid for in full.
2. Minor imperfections
  - Minor imperfections that do not affect the product's structural integrity;
  - Variations in product texture or color;
  - Efflorescence;
  - Minor imperfections in shape, appearance, or dimensions covered by ASTM C1372.

## CONDITIONS OF WARRANTY – WHAT YOU MUST DO TO RECOVER UNDER THIS LIMITED WARRANTY

Prompt Notice of Defect:

Within the warranty period, you must promptly, and in no case more than one (1) year after any defect or other basis of a claim covered by this Limited Warranty is discovered or should have been discovered, notify RCP of the defect. Any claims otherwise covered by this Limited Warranty, but for which RCP did not receive notice of the defect within one (1) year from the time the problem first became known shall be barred.

## LIMITED WARRANTY CLAIM PROCEDURE

Claims under this Limited Warranty may be made in writing to RCP at 7200 Broadway Ave. N., Rochester, MN, 55906. Claims should include the following information:

1. Claimant's name, address, and phone number and the installation address (if different);
2. A description of the product, purchase price, date and location of purchase, and copies of invoices, if available;
3. A description of the defect(s) (photos are required); and
4. A brief summary of attempts made to address the concerns.

## NO STATEMENT OF USEFUL LIFE

This Limited Warranty is not a statement of the useful life of any RCP products.

z.us.51883281.01



Pavers/Slabs	K = With KolorLast															
	Antique Brown	Antique Copper	Beechwood	Bluestone	Brown	Buff	Carmel	Cascade	Desert Buff	Moonlight Gray	Onyx	Natural	Rosewood	Santa Fe	Sierra Gray	Tuscan Red
American Brick					K	K					K					K
Barrington/Minnetonka	K		K	K				K						K		
Broadmour 6cm								○			K	○				
Broadmour 10cm Plank			○					○			K	○				
Bullnose Paver					○	○					○	○				
Cobble Stone			○						○		K					
Colonial		○	○						○							
Colonial 4x6 and 6x9					○	○					K	3/4 Sq.				
Flagstone	○													○	○	
Holland 6cm		○	○		○	○			○		K	○	○			
Holland-Eco			○					○								
Lamont	○		○		8 x 4 8 x 6				8 x 4 8 x 6		8 x 4 8 x 6			○	○	
Mezzano/Serano	K		K	K							K			K		
Tahoe/Reno			○	○										○		
6 x12 Accent (Smooth/Slate)					K	K					K	Smooth Only				

- Special Order Pavers:**
- Broadmour 10cm (except Plank)
  - Colonial 8cm
  - Holland 8cm
  - Turfstone-Eco

- Special Order Walls:**
- Big Step
  - Classic 8 Colonial
  - Keystone Standard
  - Legend
  - StoneHedge 6

\*Barn Plank tiles are manufactured with a surface applied protectant to help resist the harmful effects of time, Mother Nature, acid rain and stains.

**Need a special color?** Paver and block custom color production runs are available. Set-up fees apply, minimum quantities required and customer must take 100% of product run. Inquire with your regional RCP Sales Representative for details.

Tiles, Steps, Caps, Garden Wall and Edging	Beechwood	Brown	Buff	Bluestone	Carmel	Charcoal	Cream	Fond du Lac	Gray	Indiana Limestone	Ivory	Mahogany*	Natural	Red Black	Sandstone	Santa Fe	Weathered Gray*
Antique Travertine Tiles											●		●				
Barn Plank Tiles & Wall												●					●
Bullet Edger	●		●			●							●				
Classic® Edger		●				●		●						●	●		
Chiselled Steps			●	●						●							
Chiselled Pillar, Seatwall, Fire Ring Caps			●	●						●							
Granite Edger				●												●	
Grand Step	●		●			●							●				
Slate Tiles				●			●	●									
Stepping Stones			●	●						●							



Retaining Walls	Beechwood	Bluestone	Buff	Brown	Cascade	Charcoal	Copper Canyon	Moonlight Gray & Carmel	Fond du Lac	Gray	Onyx	Pacific Gray	Sandstone	Sandstone/Brown	Santa Fe
Classic 6		Str. and Bev.				Str.				Str.			Str.	Str. and Bev.	Str. and Bev.
Classic 8				Str.						Str. and Bev.			Str. and Bev.	Str.	
Classic 8 DOT/Cap										Str.			Str.		
Classic 8 Chiseled		●													●
Classic Colonial		●												●	●
Contemporary	●				●						●				
Cottage Stone				●		●				●			●	●	
Lakeland/Riverland	●	●			●						●				●
Rosetta Walls						●			●			●			
Sapphire	●				●					●			●		●
Stonegate C. Manor	●	●			●										●
Vintage 6 - Tumbled & Split	●	●			●										●
Versa-Lok Std.			●					●							

Wall Cap	Beechwood	Bluestone	Brown	Cascade	Charcoal	Gray	Sandstone	Sandstone/Brown	Santa Fe
4" Universal		●	●		●	●	●	●	●
3" Universal	●	●				●			●
3" Tumbled	●	●		●					●
Mini Cap			●		●	●	●	●	

Product availability subject to change. Refer to actual product samples when making color selection.



**Rochester Concrete Products**

**Corporate Office**  
7200 Broadway Ave. N.  
Rochester, MN 55906  
Phone (507) 288-8850  
Fax (507) 535-1487

**[www.rochestercp.com](http://www.rochestercp.com)**

© Copyright 2021, Rochester Concrete Products. All Rights Reserved. All trademarks and registered trademarks are the property of their respective owners. Rockwood Retaining Walls products are made worldwide under license from Rockwood Retaining Walls, Inc. US and international patents issued and pending. The information presented here has been prepared for the benefit of customers interested in Rochester Concrete Products, it was reviewed carefully prior to publication. Rochester Concrete Products assumes no liability for its accuracy or completeness. Final determination of the suitability of any information or material for the use contemplated, or for its manner of use, is the sole responsibility of the user. PROPOSITION 65 WARNING: These Products, the fuel used in this Products and other wood and charcoal burning appliances, and the combustion products of such fuels contain chemicals known to the State of California to cause cancer, or birth defects or other reproductive harm. 121

